

CCPG MEETING  
Senate Bill 100  
Stakeholder Update  
**Tuesday, August 20, 2008**



# 2008 – 2009 Process

- **March 4, 2008: Kickoff Meeting ( completed)**
- **April – July 2008: Transmission Study Groups( completed)**
- **August 20, 2008: CCPG**
- **September 26: Stakeholder Meeting**
- **November 2008: Issue Transmission Plans**
- **November 2008 – January 2009: CPCN Studies**
- **March 2009: File CPCN Applications**
- **October 31, 2009: SB100 Filing**



# Process

- **Identify Energy Resource Zones**
- **Prepare Transmission Base Cases**
- **Propose Resource Scenarios**
- **Develop Transmission Plans**



# Study Process

- Evaluate individual injection sites in each zone independently
- Identify system deficiencies and potential transmission upgrades
- Identify common solutions for multiple injection sites and zones and combine into multi-purpose projects
- For each project, identify range of injection capabilities.
- Coordinate with long range studies
- Develop and propose transmission plans



# Energy Resource Zones

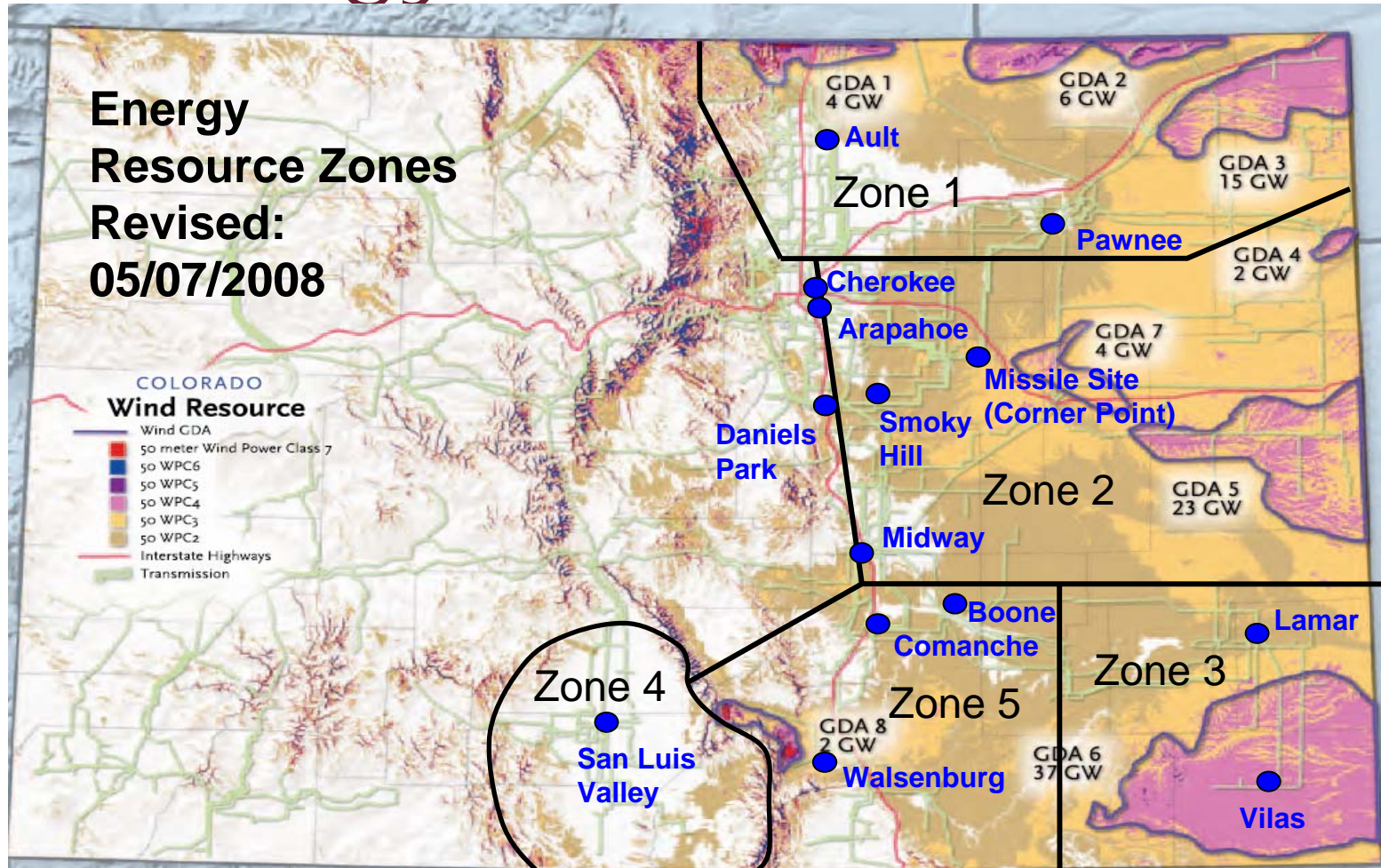

# 2015 Base Case

- **Developed from 2013 WECC High Summer Case**
- **Escalated load forecasts**
- **Added appropriate transmission projects**
- **Model injection sites for renewable and other generation in all five Energy Resource Zones**





# Injection Sites

- **Zone 1**
  - ▣ Pawnee ( 500-1000 MW)
  - ▣ Ault (500 - ? MW)
- **Zone 2**
  - ▣ Corner Point (Missile Site) ( 500 - ? MW)
- **Zone 3**
  - ▣ Lamar/Vilas (500 - ? MW)
- **Zone 4**
  - ▣ San Luis Valley (400 – 1000 MW)
- **Zone 5**
  - ▣ Walsenburg (200 - 300 MW)
  - ▣ Boone (50 MW)



# Potential Transmission Projects Zones 1 & 2

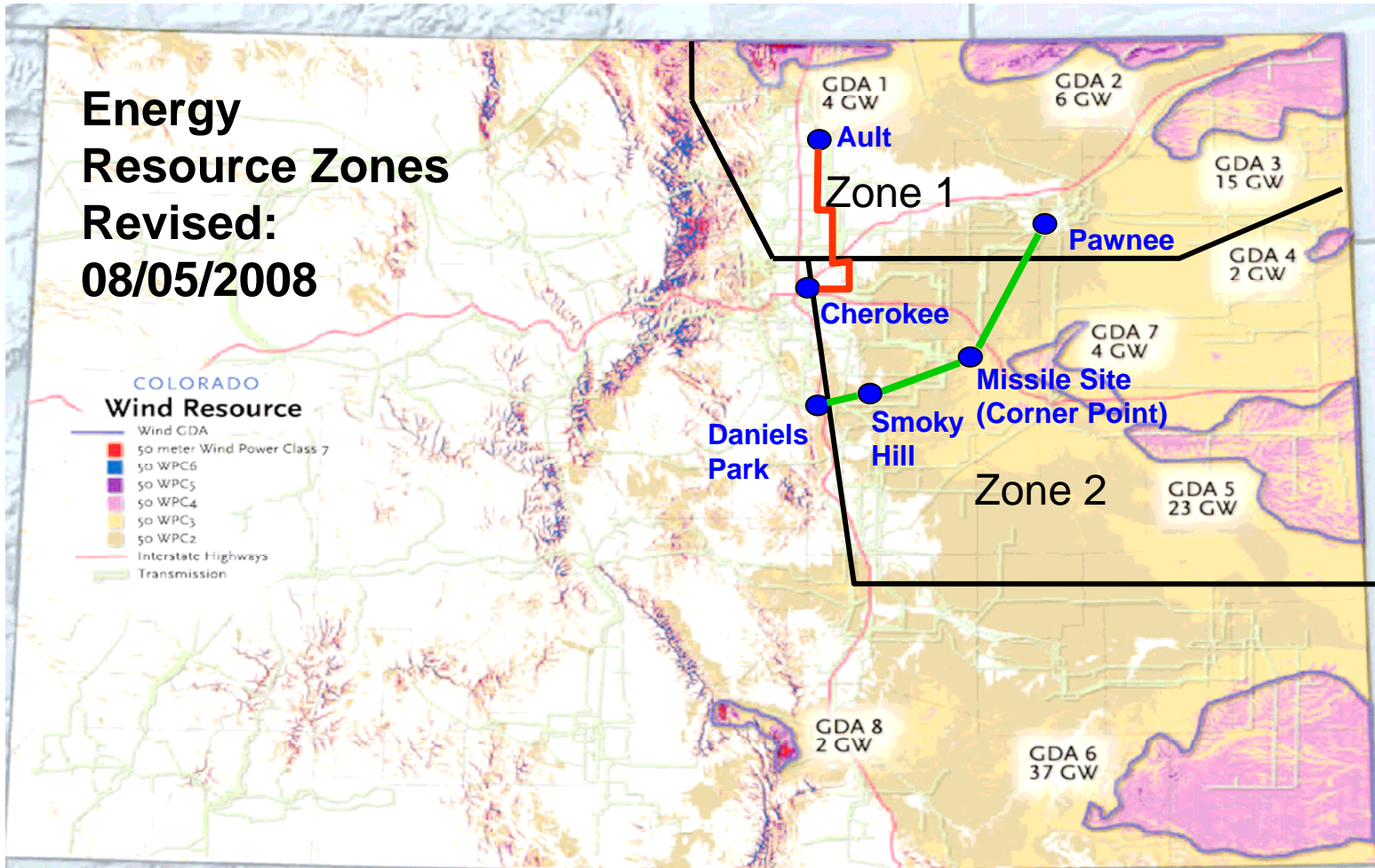

230kV  
345kV





# Zone 1 North Alternative 1

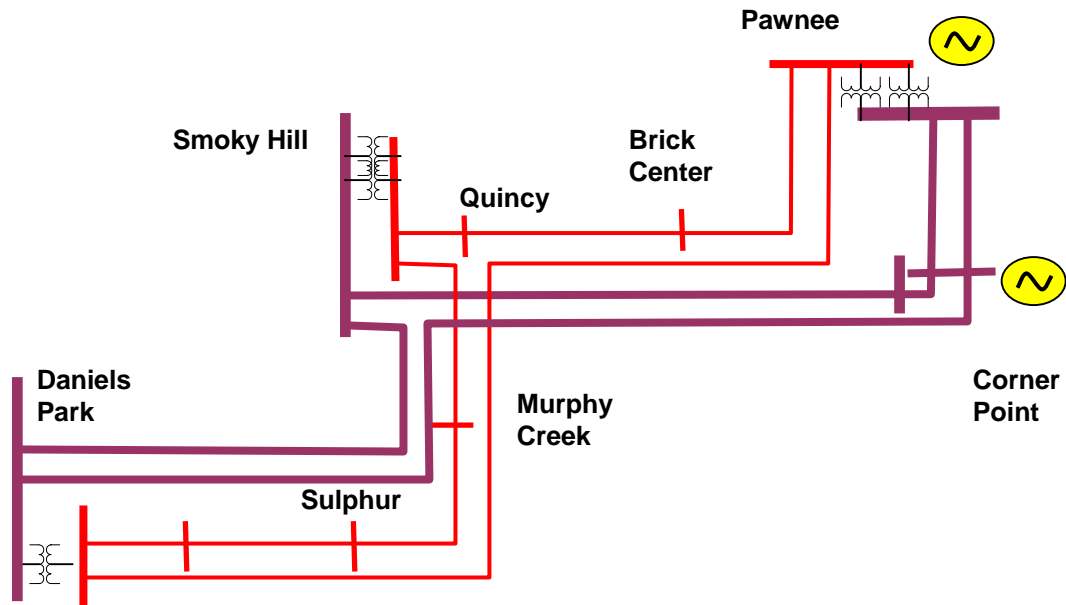

# Zone 2 Alternative 1

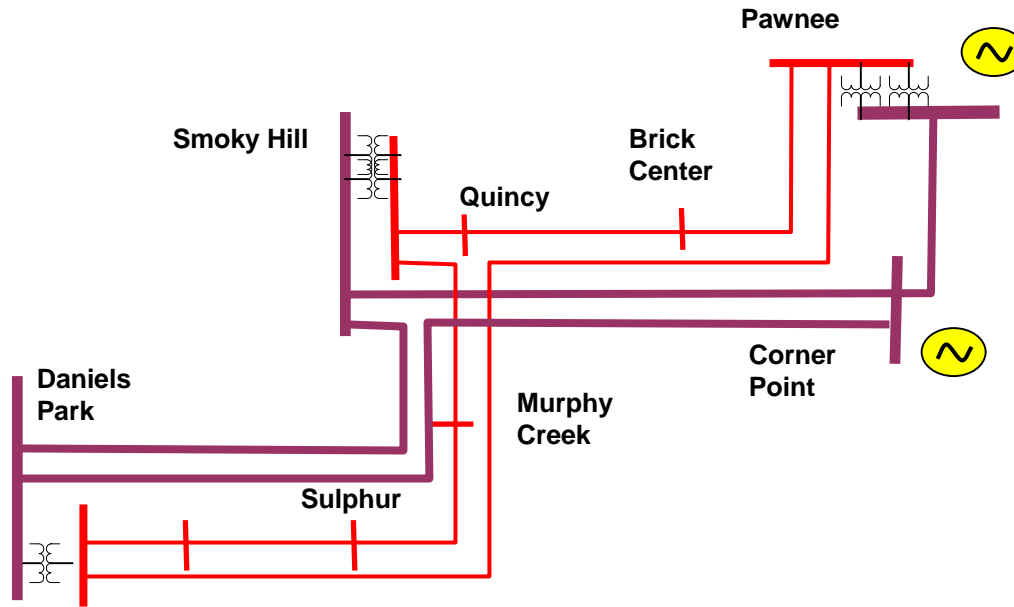

# Zone 2 Alternative 2

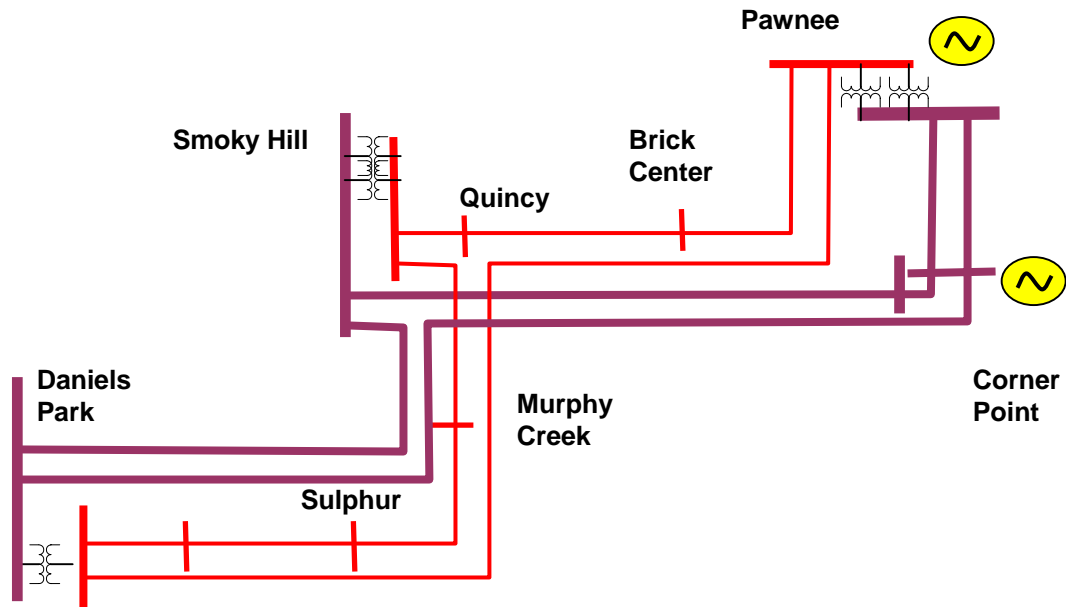

# Potential Transmission Projects Zones 3, 4, & 5

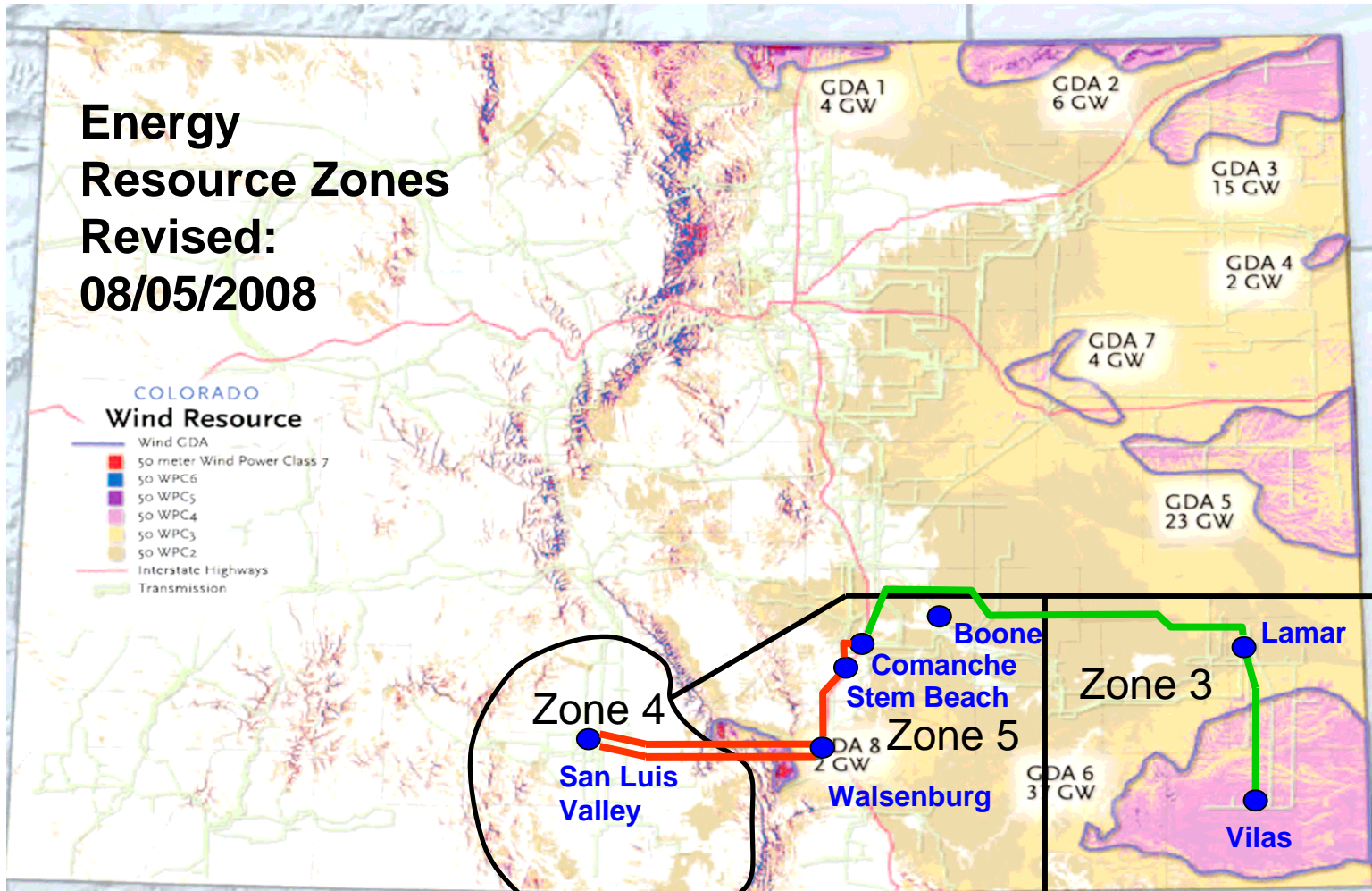

230kV  
345kV



# South Benchmark

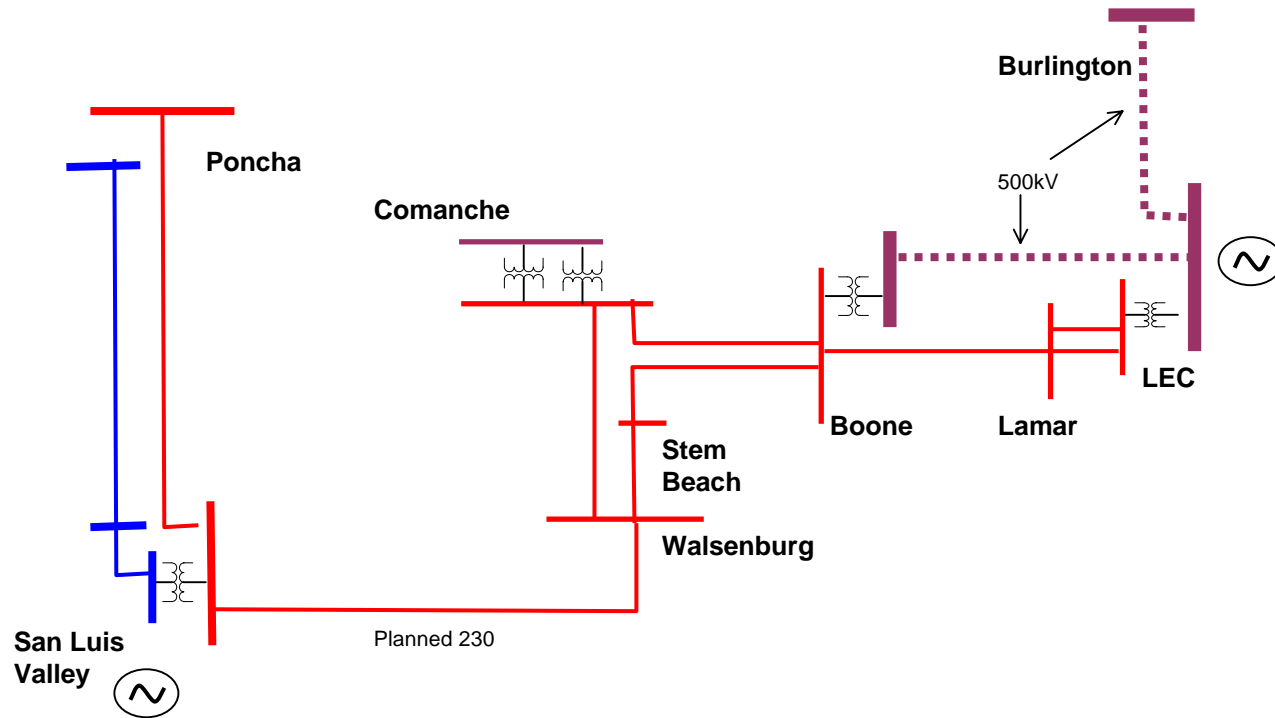



# South Revised Benchmark

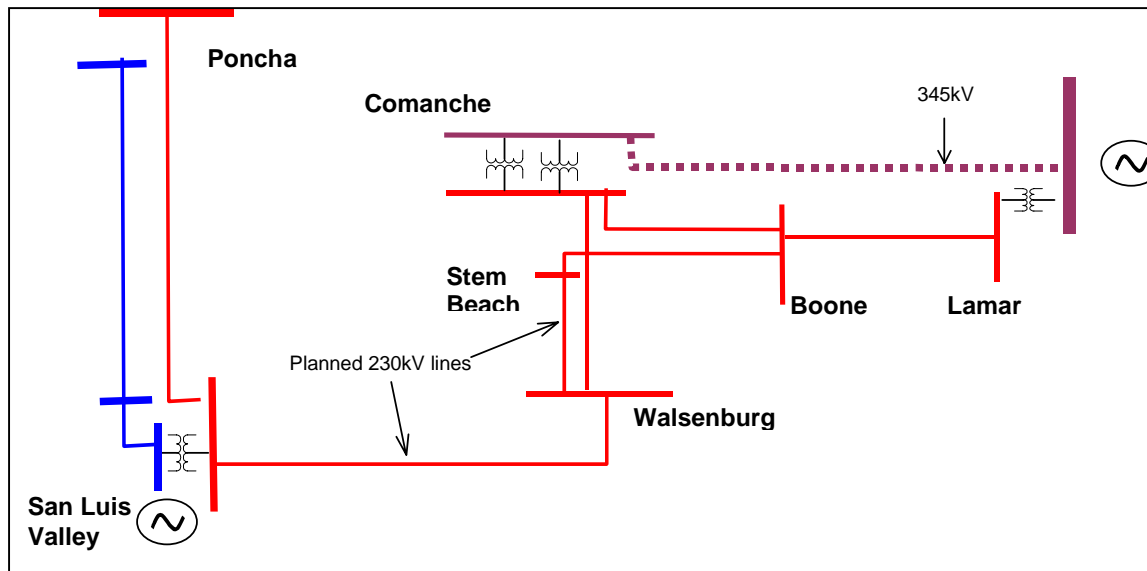

# South Alternative 1

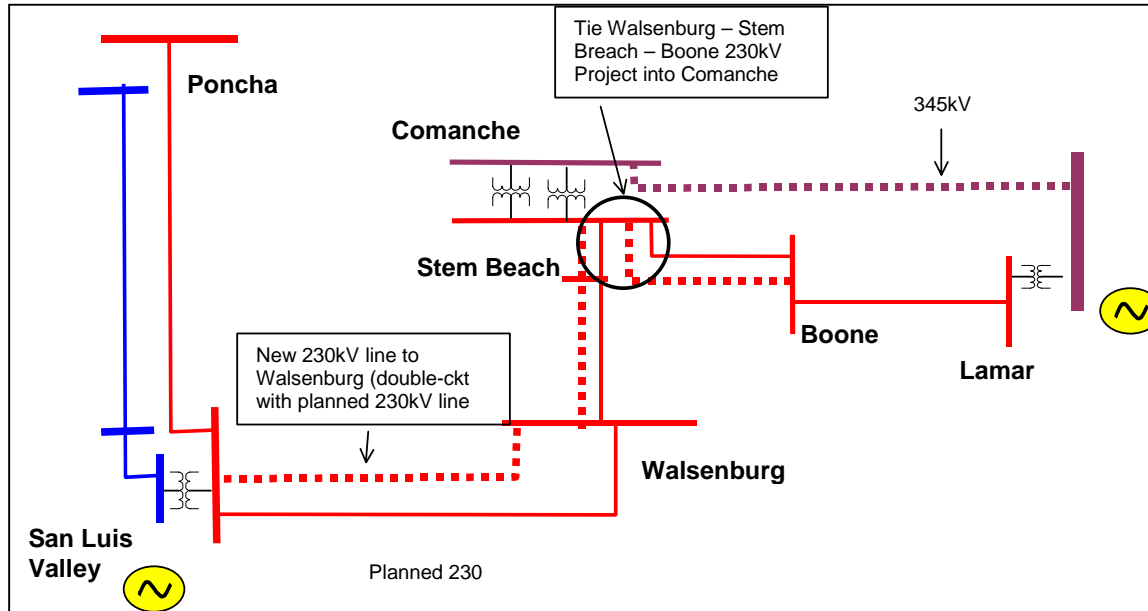

# South Alternative 2

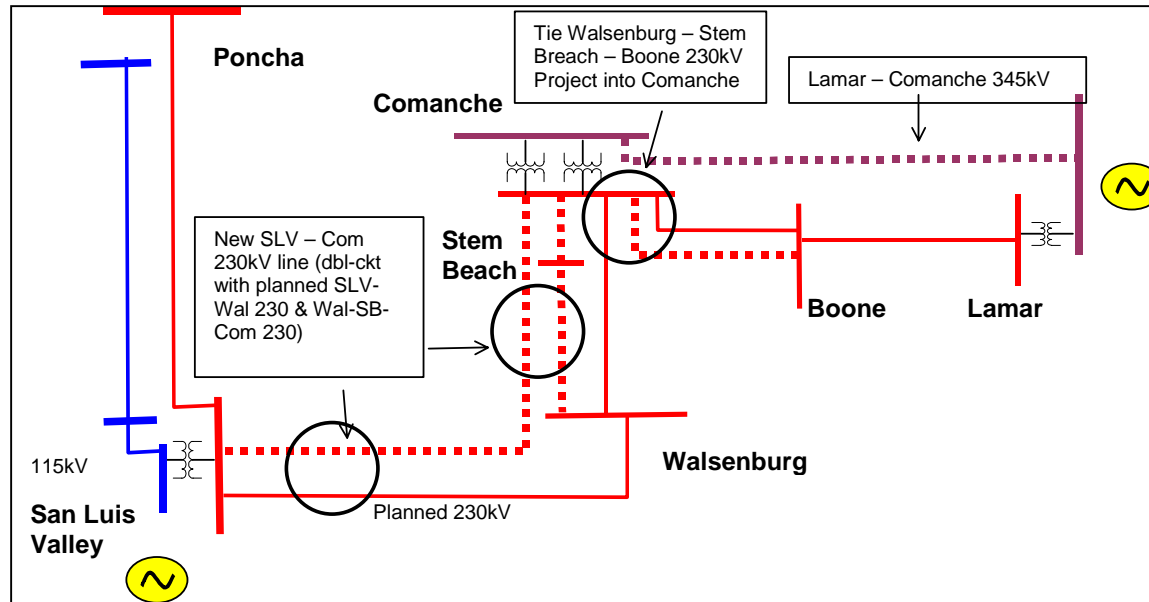

# Overall Plan

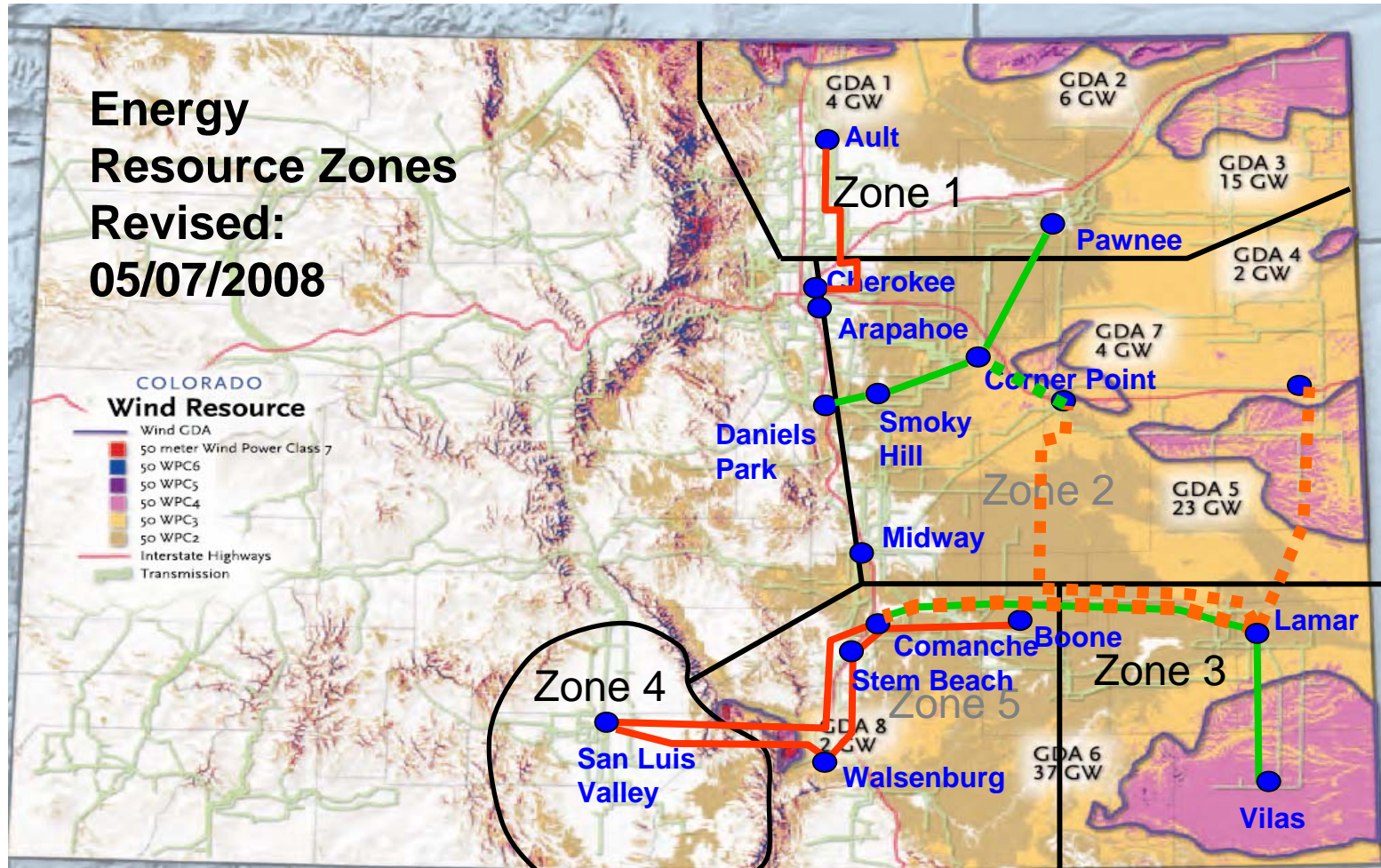

# Remaining Schedule

- **September 26, 2008 Stakeholders meeting**
- **November 2008: Issue Transmission Plans**
- **November 2008 – January 2009: CPCN Studies**
- **March 2009: File CPCN Applications**





# Questions



# PSCo Public Website

<http://www.rmao.com/wtpp/SB100.html>

