

PSCo Senate Bill 100 Stakeholder Kickoff

Tuesday, March 4, 2008



Background

- **Status of Pawnee – Smoky Hill CPCN**
- **Cost of Project: \$120 million**
- **Scheduled In Service Date: May 2013**
- **Anticipated Decision of PUC by May 1, 2008**



Pawnee - Smoky Hill CPCN

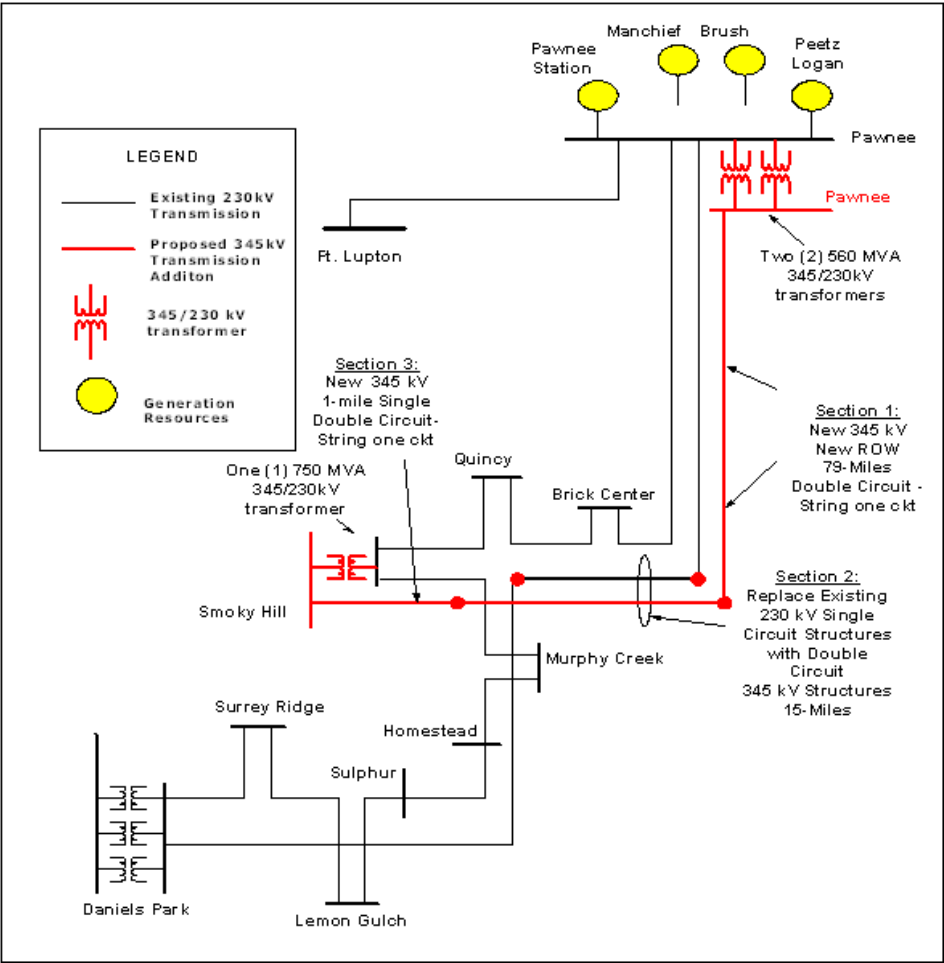

2008 – 2009 Process

- **March 4, 2008: Kickoff Meeting**
- **April – July 2008: Transmission Study Groups**
- **November 1, 2008: Issue Transmission Plans**
- **November 2008 – January 2009: CPCN Studies**
- **March 1, 2009: File CPCN Applications**
- **October 31, 2009: File Transmission Plans**



Transmission Planning Process

- **Transmission Study Groups**
- **Weekly Meetings**
- **CCPG Coordination**



Near Term Schedule

- **March 4, 2008 (PSCo 17th Street)**
 - **0900 – 1200: SB 100 Stakeholder Kickoff**
- **March 11, 2008 (PSCo TSB)**
 - **0830 – 1200: FERC 890 Attachment K Meeting**
 - **1300 – 1500: CLRTPG – Review Primary Results**
- **March 18, 2008 (Tri-State)**
 - **0900 – 1200: PSCo SB 100 Meeting**
 - **1300 – 1500: CLRTPG – Review Results**
- **March 25, 2008 (Tri-State)**
 - **0830: CCPG Meeting**
- **April 1, 2008 (PSCo TSB)**
 - **1000 – 1200: PSCo SB 100 Meeting**
 - **1300 – 1500: CLRTPG – Review Results**
- **April 8, 2008 (Tri-State)**
 - **1000 – 1200: PSCo SB 100 Meeting**
 - **1300 – 1500: CLRTPG**



Modeling Assumptions

- **WECC Base Case**
- **2015 Load Model**
- **Possible Scenarios**
 - ▣ **PSCo ERP**
 - ▣ **High Solar – Zone 4**
 - ▣ **High Wind – Zone 3**
 - ▣ **High Wind – Zone 1**
 - ▣ **Other Suggestions**



Long Range Studies

- **Currently working on 10 year long term planning study with CCPG and Stakeholders**



High Plains Express

- **Feasibility Study completed**
 - **Study report scheduled to be released March 31, 2008**
- **Executive Team formed**
 - **Moving to Phase 2**
 - **Looking at implementation: detailed studies, partnerships, economics**
- **Website:**
http://www.rmao.com/wtpp/HPX_Studies.html

