



Interconnection Feasibility Study Report Request # GI-2010-13

30 MW Solar Photovoltaic Generation
Pueblo County, Colorado

Public Service Company of Colorado
Transmission Planning
December 21, 2011

Executive Summary

Public Service Company of Colorado (PSCo) received an interconnection request (GI-2010-13) for a 30 MW solar photovoltaic generation facility in Pueblo County, Colorado. The interconnection request was received on October 19, 2010. The solar generation facility will consist of sixty, 0.5MW Sunny Central SMA SC500HE-11 inverters

The Customer requested a primary Point of Interconnection (POI) on the Boone 115 kV bus. The solar facility will be located 9 miles from the Boone Substation and connected to the POI using a 115 kV line. An alternative POI has been requested on the Boone-Comanche 230 kV line, approximately 9 miles from the Boone Substation. The solar facility will be located adjacent to the 230 kV tap. The solar facility will be connected to the alternative POI using a 230 kV line. The secondary alternative will be evaluated only if the primary POI is not feasible. Both of the proposed POIs are shown in Figure 1 below. The requested in-service date is November 1, 2013. The assumed backfeed date is May 1, 2013. Based on the construction schedule in Table 2, the Interconnection will not be able to meet the proposed back feed date of May 2013.

This request was studied as an Energy Resource only. The studies were performed using 2013 heavy summer conditions. These investigations included steady-state power flow and short circuit analyses. The request was studied as a stand-alone project only, with no evaluations made of other potential new generation requests that may exist in the Generator Interconnection Request queue, other than the generation projects that are already approved and planned to be in service by July 2013. The main purpose of this Feasibility Study was to evaluate the potential impact on the PSCo transmission infrastructure as well as that of neighboring utilities when injecting the additional 30 MW of generation into the Boone 115 kV substation or the Boone-Comanche 230 kV line, and delivering the additional generation to native PSCo loads.



Energy Resource (ER)

For the primary point of Interconnection (Boone 115 kV POI), there were no new overloads and none of the existing overloads increased by greater than 1%. The largest increase in overload was 0.4% on the Comanche-Walsenburg 230 kV line for the single contingency outage of Pueblo Tap-Stem beach 115 kV line and single contingency outage of Pueblo Tap-West Station 115 kV line. Therefore, the Boone 115 kV POI is feasible to interconnect to proposed generation facility to the PSCo system as an Energy Resource.

ER = 30 MW (at Boone 115 kV POI)

Since the primary POI is feasible, the secondary POI was not studied

Short Circuit

The short circuit study results showed no new circuit breakers overdutied due to the proposed solar generation facility.

Cost Estimates

Boone 115 kV Primary POI

The cost for the transmission interconnection (in 2011 dollars):

Transmission Proposal

The total estimated cost of the recommended system improvements to interconnect the project is approximately **\$2,054,000** and includes:

- \$ 2.054 million for PSCo-Owned, Customer-Funded Interconnection Facilities
- \$ 0.000 million for PSCo-Owned, PSCo-Funded Network Upgrades for Interconnection
- \$ 0.000 million for PSCo Network Upgrades for Delivery to PSCo Loads

This work can be completed in 18 months following receipt of authorization to proceed. The November 2013 in service date is infeasible based on the construction schedule and needs to be reevaluated.

The Interconnection Agreement (IA) requires that certain conditions be met, as follows:

- 1 The conditions of the Large Generator Interconnection Guidelines (SGIG) are met.

- 2 PSCO will require testing of the full range of 0 MW to 30 MW operational capability of the facility to verify that the facility can safely and reliably operate within required power factor and voltage ranges.
- 3 A single point of contact needs to be provided to PSCO Operations to facilitate reliable management of the transmission system.

Figure 1 Comanche, Midway, Boone and Surrounding Transmission System

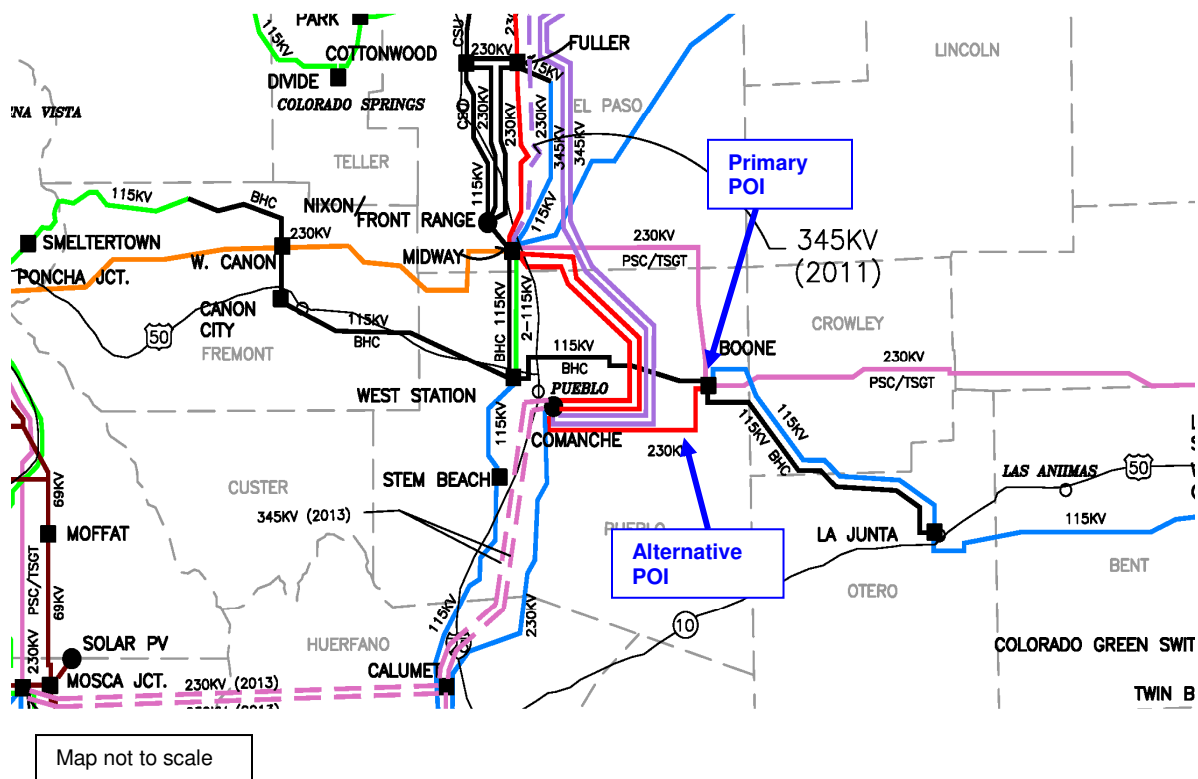

Introduction

Public Service Company of Colorado (PSCo) received an interconnection request (GI-2010-13) for a 30 MW solar photovoltaic generation facility in Pueblo County, Colorado. The interconnection request was received on October 19, 2010. The solar generation facility will consist of sixty 0.5MW Sunny Central SMA SC500HE-11 inverters. The solar facility will include 30, 270/34.5 kV, 1200 kVA transformers, it will be stepped up to 115 kV or 230 kV voltage depending on the POI and connected to the POI through a customer owned tie line.

The Customer requested a primary Point of Interconnection (POI) on the Boone 115kV bus. The solar facility will be located 9 miles from the Boone Substation and connected to the POI using a 115 kV line. An alternative POI has been requested on the Boone-Comanche 230 kV line, tapping at approximately 9 miles from the Boone Substation. The solar facility will be located adjacent to the 230 kV tap and connected to the POI using a 230 kV line. The secondary POI will be evaluated only if the primary POI is not feasible. Both of the proposed POIs are shown in Figure 1 below. The requested in-service date is November 1, 2013. The assumed backfeed date is May 1, 2013. Based on the construction schedule in Table 2, the Interconnection will not be able to meet the proposed back feed date of May 2013.

Study Scope and Analysis

The Feasibility Study evaluated the transmission impacts associated with the proposed solar generation facility. It consisted of power flow and short circuit analyses. The power flow analysis identified any thermal or voltage limit violations resulting from the installation of the proposed generation and an identification of network upgrades required to deliver the proposed generation to PSCo loads. The short circuit analysis identified any new circuit breakers overdutied due to the proposed generation and the short circuit levels at the primary POI.

PSCo adheres to NERC & WECC Reliability Criteria, as well as internal Company criteria for planning studies. During system intact conditions, criteria are to maintain transmission system bus voltages between 0.95 and 1.05 per unit of nominal, and steady-state power flows below the thermal ratings of all facilities. Operationally, PSCo tries to maintain a transmission system voltage profile ranging from 1.02 per unit or higher at regulating (generation) buses to 1.0 per unit or higher at transmission load buses. Following a single contingency, transmission system steady state bus voltages must remain within 0.90 per unit to 1.05 per unit, and power flows within 100% of the facilities' continuous thermal ratings. Also, voltage deviations should not exceed 5%.

The proposed facility was studied as an Energy Resource only. Energy Resource Interconnection Service shall mean an Interconnection Service that allows the Interconnection Customer to connect its Generating Facility to the Transmission



Provider's Transmission System to be eligible to deliver the Generating Facility's electric output using the existing firm or non-firm capacity of the Transmission Provider's Transmission System on an as available basis. Energy Resource Interconnection Service in and of itself does not convey transmission service.

For this project, potential affected parties include Tri-State Generation & Transmission (TSG&T), Colorado Springs Utilities (CSU) and Black Hills Energy (BHE).

Power Flow Study Models

The solar facility interconnection was studied using 2013 heavy summer loading conditions. The 2013HS case was built using the WECC approved 2012HS3SA base case. PSCo loads in the case were adjusted to reflect the most recent (April 2011) PSCo load forecast for 2012. The topology was also updated to reflect current project plans and rating changes for 2013. Updates were included for CSU, TSGT, BHE and WAPA systems per their submittals. PSCo updates included the addition of 40 Mvar reactors at Comanche 345 kV and Daniels Park 345 kV, correct impedance of the Missile Site-Daniels Park and Missile Site-Pawnee 230kV circuits, Missile Site 345 kV Substation and associated wind generation, removed Wolfensberger, Franktown, Delbert and Spring Valley and Benett substation models. The updates also included the wind plant at Missile Site 230kV Substation and a second 230/115 kV transformer at Chambers. BHP's updates include upgrades to the existing Portland-West Station 230 kV line and a second Portland – West Station 230 kV line.

Two main power flow generation dispatch scenarios were evaluated. One was created as a reference scenario and the other was created with the proposed generation. To assess the impact of the proposed generation on the transmission system, the power flow models were modified to simulate higher flows from southern Colorado to the north. To accomplish this, generation in south-central Colorado was dispatched to maximum output to increase flows to the north. Generation increases were implemented at Comanche Units 1-3 and the Colorado Green & Twin Butte wind farms. The new 400 MW BHE generation at Airport Tap, wind generation at Rattlesnake and Pueblo Generation were also included. Generation at Manchief Units 1 & 2 and Fort Saint Vrain Units 5 & 6 were used as sink for the dispatch changes. PSCo control area (Area 70) wind generation facilities except for Colorado Green and Twin Butte were dispatched to 12.5%.

In the cases with the proposed generation, the 30 MW of new solar generation was modeled as a lumped machine with maximum real power capability of 30 MW and minimum real power capability of 0 MW. The solar facility will be located 9 miles from the Boone 115 kV Substation. The 115 kV transmission tie line was modeled using the 115 kV line parameters provided by the Customer. The secondary alternative will be evaluated only if the primary POI is not feasible. The power factor of the proposed

generation was set to unity for the thermal analysis. The new generation was offset by reducing generation at Spindle unit 1.

Power Flow Study Process

Contingency power flow studies were completed on the reference models and the models with the proposed new generation using PTI's PSSE Ver. 32.1.0 program. Results from each of the two cases were compared and any new overloads or existing overloads that increased by at least 1% in the new generation case were noted. Voltage criteria violations were also recorded. PSSE's ACCC activity was used to perform the load flow contingency analysis. Areas 70 and 73 were used for the contingency files (single branches and tie lines). Monitored elements included branches and ties in zones 700, 704, 705, 709, 712, 757, 790 and 791.

Power Flow Results

Boone 115 kV POI

The proposed solar facility has not caused any thermal violations, no new overloads were caused and none of the existing overloads found in the benchmark case increased by greater than 1%. The largest increase in overload was 0.4% on the Comanche-Walsenburg 230 kV line for the single contingency outage of Pueblo Tap-Stem beach 115 kV line and single contingency outage of Pueblo Tap-West Station 115 kV line. Also, no new bus voltage limit violations were found.

Therefore, the Energy Resource Capability of the proposed generation is:

ER = 30 MW (at Boone 115 kV)

Since the primary POI is feasible, the secondary POI was not evaluated

Short Circuit

For the Customer proposed interconnection at the Boone 115 kV primary POI, no new circuit breakers are expected to exceed their capabilities following installation of the new generation. The calculated short circuit parameters for the POI at the Boone 115 kV substation are shown in Table 1 below.

Table 1 – Short Circuit Parameters at the Boone 115 kV POI

System Condition	Three-Phase Fault Level (Amps)	Single-Line-to-Ground Fault Level (Amps)	Thevenin System Equivalent Impedance (R +j X) (ohms)
All Facilities in Service	8589.9	8423.5	Z1(pos)= 0.69621 +j 7.69803 Z2(neg)= 0.69658 +j 7.69777 Z0(zero)= 0.85678 +j 8.14340



Costs Estimates and Assumptions

GI-2010-13 (Feasibility Study Report)

Scoping level cost estimates for Interconnection Facilities and Network/Infrastructure Upgrades for Delivery (+/- 30% accuracy) were developed by PSCo Engineering. The cost estimates are in 2011 dollars with escalation and contingencies applied (AFUDC is not included) and are based upon typical construction costs for previously performed similar construction. These estimated costs include all applicable labor and overheads associated with the siting support, engineering, design, and construction of these new PSCo facilities. This estimate does not include the cost for any other Customer owned equipment and associated design and engineering.

The estimated total cost for the required upgrades is **\$2,054,000**. Figure 2 below represents a conceptual one-line of the proposed interconnection at the Boone 115kV Substation. These estimates do not include costs for any other Customer owned equipment and associated design and engineering. The following tables list the improvements required to accommodate the interconnection and the delivery of the Customer's 20MW solar generation output. The cost responsibilities associated with these facilities shall be handled per current FERC guidelines. System improvements are subject to change upon completion of the Facility Study.

Figure 2: Proposed Boone Station One-line with Project Interconnection

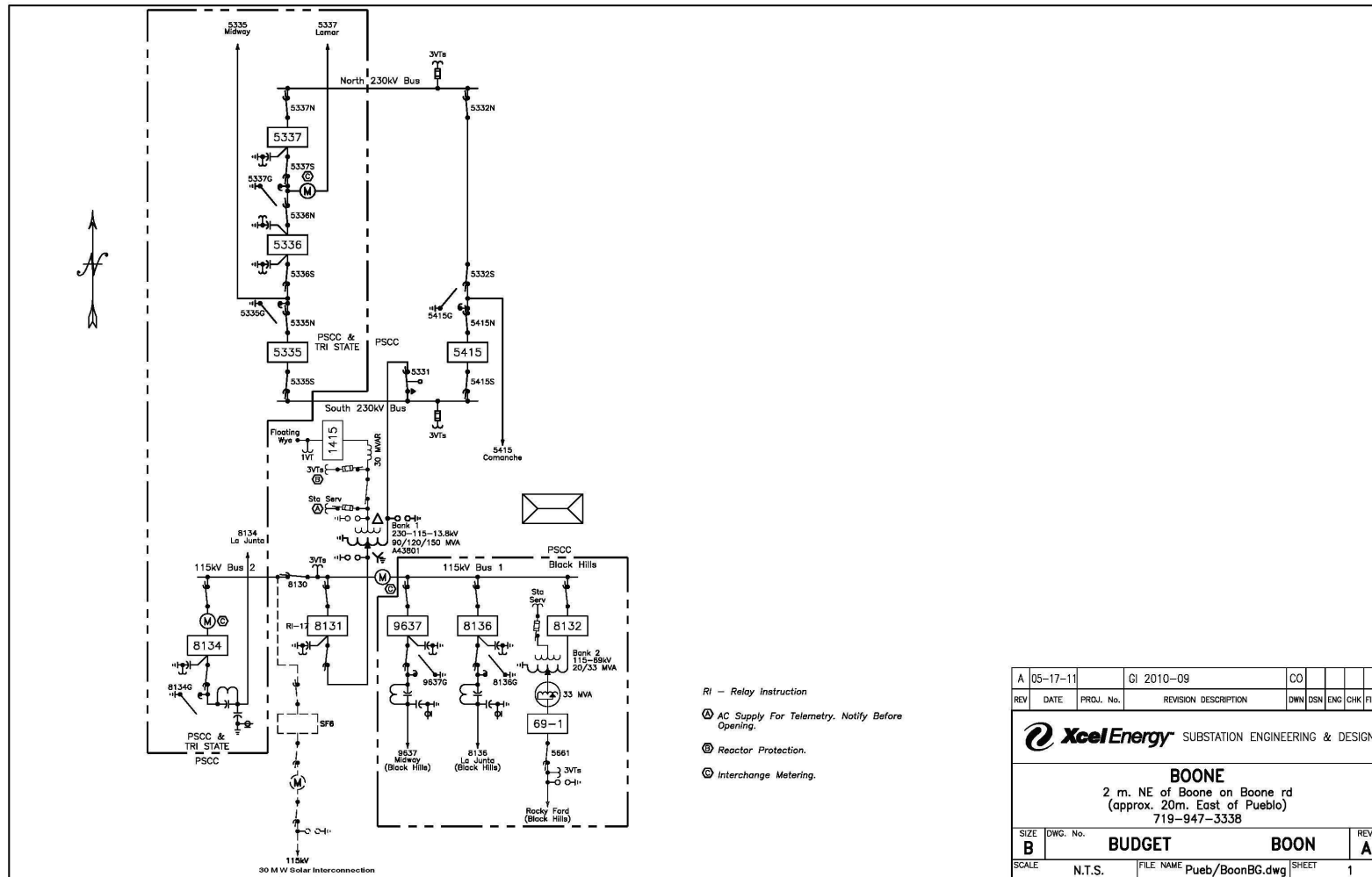

A	05-17-11		GI 2010-09	CO				
REV	DATE	PRD. No.	REVISION DESCRIPTION	DWN	DSN	ENG	CHK	FILM
SUBSTATION ENGINEERING & DESIGN								
BOONE 2 m. NE of Boone on Boone rd (approx. 20m. East of Pueblo) 719-947-3338								
SIZE	DWG. No.	BUDGET		BOON		REV.		
B						A		
SCALE	N.T.S.	FILE NAME	Pueb/BoonBG.dwg	SHEET	1			

Table 2 – PSCo Owned; Customer Funded Transmission Provider Interconnection Facilities

Element	Description	Cost Est. (Millions)
PSCo's Boone 115kV Transmission Substation	Interconnect Customer to the 115kV bus at the Boone 115kV Substation. The new equipment includes: <ul style="list-style-type: none"> • Three 115kV gang switches • One 115kV circuit breaker • Two 115V combination CT/PT metering units • Power Quality Metering (115kV line from Customer) • Three 115kV lightning arresters • One relay panel (transformer breaker panel) • Associated communications, supervisory and SCADA equipment • Associated line relaying and testing • Associated bus, wiring and equipment • Associated foundations and structures • Associated transmission line communications, relaying and testing 	\$1.891
Customer's 115kV Substation	Load Frequency/Automated Generation Control (LF/AGC) RTU and associated equipment.	\$0.163
	Total Cost Estimate for PSCo-Owned, Customer-Funded Interconnection Facilities	\$2.054
Time Frame	Design, procure and construct	18 Months

Table 3: PSCo Owned; PSCo Funded Interconnection Network Facilities

Element	Description	Cost Estimate (Millions)
PSCo's Boone 115kV Transmission Substation	N/A	\$0.0
		\$0.0
	Total Cost Estimate for PSCo-Owned, PSCo-Funded Interconnection Facilities	\$0.0
Time Frame	Site, design, procure and construct	N/A

Table 4 – PSCo Network Upgrades for Delivery

Element	Description	Cost Est. (Millions)
	Not Applicable	
	Total Cost Estimate for PSCo Network Upgrades for Delivery	\$0.0
	Design, procure and construct	N/A
	Total Project Estimate	\$2.054

Cost Estimate Assumptions

- Scoping level cost estimates for Interconnection Facilities and Network/Infrastructure Upgrades for Delivery (+/- 30% accuracy) were developed by PSCo Engineering.
- Estimates are based on 2011 dollars (appropriate contingency and escalation applied).
- AFUDC has been excluded.
- Labor is estimated for straight time only – no overtime included.
- Lead times for materials were considered for the schedule.
- The Solar Generation Facility is not in PSCo’s retail service territory. Therefore, no costs for retail load metering are included in these estimates.
- PSCo (or it’s Contractor) crews will perform all construction, wiring, testing and commissioning for PSCo owned and maintained facilities.
- The estimated time to design, procure and construct the interconnection facilities is approximately 18 months after authorization to proceed has been obtained.
- This project is completely independent of other queued projects and their respective ISD’s.
- A CPCN will not be required for the interconnection facilities construction.
- Customer will string OPGW fiber into substation as part of the transmission line construction scope.
- Breaker duty study determined that no breaker replacements are needed in neighboring substations.
- Line and substation bus outages will be authorized during the construction period to meet backfeed. Could potentially be problematic and extend requested backfeed date due to summer construction window.
- Power Quality Metering (PQM) will be required on the Customer’s 115 kV line terminating into Boone Substation.



A. Generation Dispatch

Dispatch of Major Generating Units in the Vicinity of GI-2010-13:

PSCo:

<u>Bus</u>	<u>LF ID</u>	<u>MW</u>
Comanche	C1	353
Comanche	C2	362
Comanche	C3	804.0
Lamar DC Tie	DC	101.0 Import
Fountain Valley	G1	0.0
Fountain Valley	G2	0.0
Fountain Valley	G3	0.0
Fountain Valley	G4	0.0
Fountain Valley	G5	0.0
Fountain Valley	G6	0.0
Colorado Green	1	81.0
Colorado Green	1	81.0
Twin Butte	1	75.0

ARPA:

<u>Bus</u>	<u>LF ID</u>	<u>MW</u>
City of Lamar	G1	42

BHE:

<u>Bus</u>	<u>LF ID</u>	<u>MW</u>
BUSCHWRTG1	1	28.8S
E Canon	G1	0.0
PP_MINE	G1	0.0
Pueblo Diesels	G1	0.0
Pueblo Plant	G1	20
Pueblo Plant	G2	0.0
R.F. Diesels	G1	0.0
Airport Diesels	G1	0.0
Canyon City	C1	0
Canyon City	C1	0
Baculite 1	G1	100.0
Baculite 2	G1	100.0
Baculite 3	G1	40.0
Baculite 3	G2	40.0
Baculite 3	S1	20.0
Baculite 4	G1	40.0
Baculite 4	G2	40.0
Baculite 4	S1	20.0



CSU:

<u>Bus</u>	<u>LF ID</u>	<u>MW</u>
Birdsale 1	1	0.0
Birdsale 2	1	0.0
Birdsale 3	1	0.0
Nixon	1	225.0
Tesla	1	28.0
Drake 5	1	49.0
Drake 6	1	82.3
Drake 7	1	139.1
Nixon CT 1	1	0.0
Nixon CT 2	1	0.0
Front Range CC 1	1	82
Front Range CC 2	1	82
Front Range CC 3	1	116