



## Interconnection System Impact Study Report Request # GI-2007-3

### 300 MW Wind Powered Generator Interconnecting at Ault Substation PSCo Transmission Planning August 6, 2009

#### Executive Summary

PSCo Transmission received a generator interconnection request to determine the system impact of interconnecting 300 MW of new Customer wind turbine generation into the PSCo transmission system. The requested Point of Interconnection (POI) would be at the Ault Substation 230 kV bus. GI-2007-3 was studied as a 300 MW wind generation project injecting at Ault Substation. The Customer proposed commercial operation date is October 15, 2010 with a back feed date of February 15, 2010. This request was studied as both an Energy Resource<sup>1</sup> (ER) and a Network Resource (NR)<sup>2</sup>.

#### Energy Resource

The study determined that the Customer may interconnect as a Network Resource after the required Network Upgrades for Delivery are completed. Interconnection as an Energy Resource will require the same Network Upgrades to deliver the requested generation level on a firm basis. Some non-firm transmission capability may be available depending upon generation dispatch levels, demand levels, import path levels (TOT7, etc), and the operational status of transmission facilities

#### Network Resource

As an NR request, PSCo evaluated the network to determine the upgrades required to deliver the full 300 MW of the wind facility to PSCo native load customers.

---

<sup>1</sup> **Energy Resource Interconnection Service (ER Interconnection Service)** shall mean an Interconnection Service that allows the Interconnection Customer to connect its Generating Facility to the Transmission Provider's Transmission System to be eligible to deliver the Generating Facility's electric output using the existing firm or nonfirm capacity of the Transmission Provider's Transmission System on an as available basis. Energy Resource Interconnection Service in and of itself does not convey transmission service.

<sup>2</sup> **Network Resource Interconnection Service** shall mean an Interconnection Service that allows the Interconnection Customer to integrate its Large Generating Facility with the Transmission Provider's Transmission System (1) in a manner comparable to that in which the Transmission Provider integrates its generating facilities to serve native load customers; or (2) in an RTO or ISO with market based congestion management, in the same manner as all other Network Resources. Network Resource Interconnection Service in and of itself does not convey transmission service.



The PSCo system between the Ault Substation and the PSCo System includes one WECC<sup>3</sup> recognized transfer path – TOT7. The TOT 7 transfer path is a constrained interface between the Northern Colorado Area and the North Denver Metro Area. The TOT 7 transfer limit depends on the Foothills Area demand and the level of generation from the Colorado-Big Thompson (CBT) Hydro Project units.

Power flow studies demonstrate that PSCo's transmission system cannot accommodate this interconnection request at the Ault 230kV POI under the operating scenarios studied without significant transmission additions. The 300 MW power schedule would cross TOT 7 to reach the PSCo load center. TOT7 is a constrained path whose operating limit depends on the Foothills Area demand conditions and CBT generation. TOT 7 transfer capacity is fully committed by existing firm reservations and there are current system criteria violations that reduce the use of the Total Transfer Capability (TTC) on TOT7. The proposed generation interconnection project would require significant transmission additions so that the power could be delivered to load.

The recommended Network Upgrades for Delivery that will accommodate the full 300 MW from this project are listed below with an estimated total cost of the these upgrades at approximately **\$65.013 million** and include:

- \$0.890 million for Customer Funded PSCo Interconnection Facilities
- \$0.412 million for PSCo Network Upgrades for Interconnection
- \$63.711 million for PSCo Network Upgrades for Delivery

The required Network Upgrade for Delivery include the following:

- Construct a new 88-mile 230 kV transmission line using a two-conductor bundle of 954 kcmil "Cardinal" conductor per phase from the Ault Substation to Cherokee Substation. The line will consist of a single 59-mile 230 kV line (345 kV construction) from Ault to just outside of Ft. Lupton. From this point the line will become a 29-mile double circuit 230 kV line by rebuilding the existing 115 kV line from Ft. Lupton to Cherokee on 230 kV structures with one side operated at 115 kV for the Tri-State G&T (TSGT) load-serving substations and the other side operated at 230 kV completing the circuit from Ault to Cherokee. The portion of the circuit from Ft.Lupton to Cherokee could be constructed for future 345 kV operation as there is sufficient existing right-of-way; however, adding a 345 kV yard at the Cherokee Substation may not be feasible.

---

<sup>3</sup> Western Electricity Coordinating Council (WECC)



The estimated cost is a “scoping” (+/-30%) preliminary cost in 2008 dollars and is based on typical construction costs for previously performed similar construction. The estimated length of time required to complete the project is approximately 60 months<sup>4</sup>, therefore making delivery of the full 300 MW is not feasible by the requested October 15, 2010 commercial operation date.

Joint transmission studies would be required with all affected utilities to obtain regulatory and industry acceptance of a new TOT 7 transfer limit along with the proposed infrastructure improvements, if the Customer chooses to continue this interconnection request. This study did not examine or propose a new transfer limit of the path or allocate the rights between TOT 7 owners PSCo and Platte River Power Authority (PRPA). This study only examined system criteria violations before and after the integration of GI-2007-3. The WECC path rating process requires joint transmission studies to demonstrate that the new rating would not negatively impact other transfer paths and neighboring systems.

A system one-line diagram showing the proposed infrastructure to meet the delivery requirements is shown below in Figure 1 along with the interconnection details. Additional details of the studies can be found in the Appendix.

Any Interconnection Agreement (IA) requires that certain conditions be met, as follows:

1. The conditions of the Interconnection Guidelines<sup>5</sup> are met.
2. A single point of contact is given to Operations to manage the Transmission System reliably for all wind projects (GI-2007-3) as found in the Interconnection Guidelines.
3. Customer must show the ability to control power factor and provide voltage support as measured at the POI, across the required +/- 0.95 power factor range during all operating conditions (0 MW to 300 MW).

These studies determined the following:

- The Customer’s wind power generating station, at the full wind output 300 MW, would meet the voltage and power factor requirements, without installing additional static and/or dynamic VAR support equipment at either the Customer’s site or near the Western’s Ault 230 kV POI. The station is able to operate within the +/- 0.95 power factor requirement as measured at the POI for the system scenario studied (heavy summer demand case) with the wind generation facility on-line.

---

<sup>4</sup> Assumptions at the end of the report state that 60 months includes the Colorado CPCN process for the recommended Network Upgrades for Delivery.

<sup>5</sup> Interconnection Guidelines for Transmission Interconnected Producer-Owned Generation Greater than 20 MW, version 3.0 12/31/06.



- The Customer' wind power generating station, with the generating station off-line at 0 MW, would not meet PSCo's +/- 0.98 power factor requirement for loads as measured at the POI. During that condition, the generating facility is operating as a load for station service and approximately 26 MVAR is injected from the Customer's 230 kV transmission line into the Ault 230 kV POI. Therefore, the Customer would need to install inductors so that the facility can operate within the required power factor range for a load (between 0.98 leading and lagging power factor) when the wind generation facilities are off-line.
- The Customer's wind power generating station of 300 MW connected to the Ault 230 kV bus with network upgrades (an Ault-Cherokee 230 kV line) does not have an adverse impact on the response of the system to severe system disturbances. All generation remained on line, except where disconnected from the system. All oscillations were positively damped and voltage deviations on nearby 115 kV and 230 kV buses were well within criteria, with no low voltage ride-through (LVRT) issues.

Western owns the Ault Substation. Interconnecting at the Ault Substation would require Western to design and construct new facilities at the Ault Substation. PSCo and the developer would need to work with Western as an affected party to develop the interconnection design and costs.

Figure 1 Proposed Transmission Upgrades

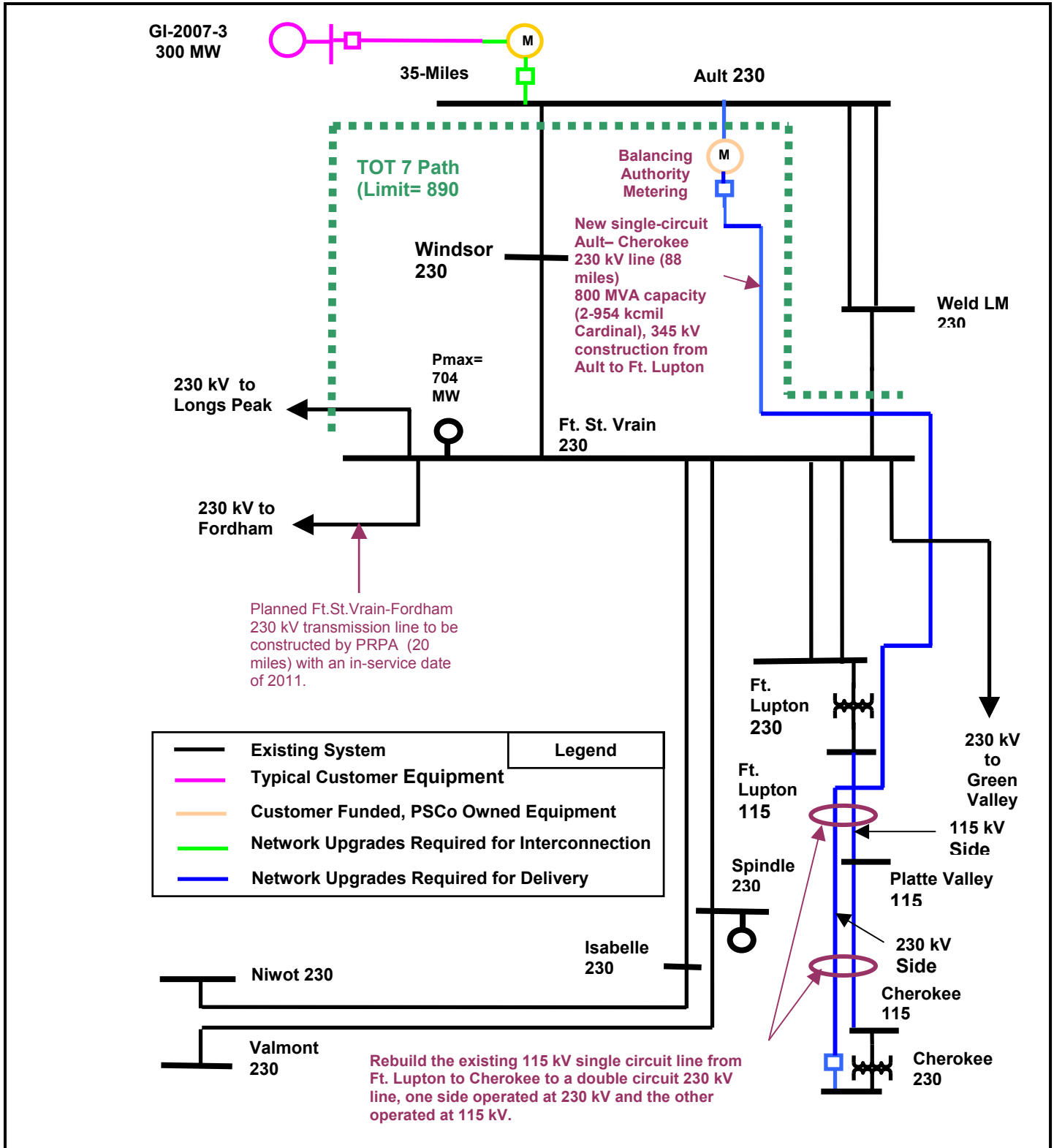



## **Introduction**

On October 3, 2007, the Customer and PSCo signed an Interconnection System Impact Study Agreement for a 300 MW wind farm that would interconnect to the Ault Substation 230 kV bus. The proposed 300 MW wind farm G-2007-3 would be located northwest of Ft. Collins, Colorado. The facility would interconnect into the PSCo transmission system via a proposed Customer-owned 35-mile radial 230 kV line terminating at the POI, the Ault Substation. The Customer requested that this Project be evaluated as a Network Resource (NR) and an Energy Resource (ER) with the energy going to PSCo customers. The Customer indicated that the wind farm would consist of 200 Acciona Windpower AW1500 (1.5 MW) wind turbine units.

## **Path Definitions**

The generation interconnection request impacts the power transfer path TOT 7<sup>6</sup>. The TOT 7 transfer path provides a path for power transfers into the northern metro Denver area and is also known as Path 40 in the WECC Path Rating Catalog. The loads in the study area consist of Zone 754 and Zone 706 in the WECC power flow case.

### **TOT 7**

TOT 7 is WECC defined power transfer path located in the study area. TOT 7 is comprised of transmission lines that allow power to be transferred between northeast Colorado and the north Denver Metro Area. The path is shown in Figure 1. The path has a maximum WECC-accepted north-to-south rating of 890 MW; however, the real-time path rating is highly dependant on the level of demand in the Foothills Area and the on-line generation in the study area called the “Colorado-Big Thompson generation” or CBT. The TOT 7 path owners include Platte River Power Authority (PRPA) and PSCo. The facilities for this study that comprise TOT 7 are as follows:

<b><u>Transmission Line</u></b>	<b><u>Metered End</u></b>
Ault-Windsor 230 kV	Ault
WeldPS-Ft.St.Vrain 230 kV	Weld
Longs Peak-Ft.St.Vrain 230 kV	Ft.St.Vrain

The ability to transfer power across the TOT 7 Transfer Path is impacted by the level of Foothills Area demand and level of hydroelectric generation of the Colorado-Big Thompson system. As demand in the Foothills Area increases, the TOT 7 real-time transfer limit decreases. Similarly, as the Colorado-Big Thompson (CBT) generation decreases, the TOT 7 real time rating decreases. These variables are considered for any study that considers transfers across the TOT7 Transfer Path.

---

<sup>6</sup> The TOT 7 transfer path is shared between PSCo and PRPA.



## **Study Scope and Analysis**

The Generator System Impact Study evaluated the feasibility of providing 300 MW of firm energy from the POI at Ault Substation to the PSCo load center. The System Impact Study consisted of power flow and transient stability analyses.

PSCo adheres to NERC / WECC Reliability Criteria, as well as internal Company criteria for planning studies. The criteria used for the study can be found in Section A.2.a of this report.

## **Power Flow Study Models**

Western Electricity Coordinating Council (WECC) creates the operating and planning cases for transmission planning studies. For this study, PSCo used the 2011 HS1B approved base case (approved on January 11, 2007).

## **Power Flow Study Results and Conclusions**

Power flow studies were conducted and it was determined that significant Network Upgrades would be required to accommodate the 300 MW interconnection request and that these transmission upgrades would be needed to increase the TOT 7 transfers under heavy summer demand conditions.

Transmission alternatives were developed to allow an increase of the TOT 7 transfers assuming 2010 heavy summer demand conditions with CBT generation on-line along with the proposed 300 MW wind facility interconnecting at Ault.

The preferred alternative (Scenario 2) identified would be to construct an 88-mile Ault to Cherokee 230 kV line. The line would not interconnect at the Ft. St. Vrain or Ft. Lupton substations. This alternative allowed the 300 MW of wind generation to be scheduled across TOT 7 without violating system criteria.

## **Transient Stability Analyses Results and Conclusions**

For all contingencies studied, the results of the stability analysis indicate that the addition of Scenario 2 (a 300 MW wind generation facility connected to the Ault 230 kV bus along with an Ault-Cherokee 230 kV line) does not have an adverse impact on the response of the system to severe system disturbances. All generation remained on line, except where disconnected from the system. All oscillations were positively damped and voltage deviations on nearby 115 kV and 230 kV buses were well within criteria. The contingencies consisting of delayed clearing were similarly behaved with no undamped oscillations and voltage responses within criteria as well. Results of system



behavior in the benchmark case were similar to those observed for the case with GI-2007-3 generation and no transmission upgrades.



## Costs Estimates and Assumptions

The estimated total cost for the required upgrades for is **\$ 65.013 million**. The estimated costs shown are (+/-30%) estimates in 2008 dollars (no escalation applied) and are based upon typical construction costs for previously performed similar construction. These estimated costs include all applicable labor and overheads associated with the engineering, design, and construction of these new PSCo facilities. This estimate did not include the cost for any other Customer owned equipment and associated design and engineering.

The following tables list the improvements required to accommodate the interconnection and the delivery of the Project. The cost responsibilities associated with these facilities shall be handled as per current FERC guidelines. System improvements are subject to change upon more detailed analysis.

**Table 1 – PSCo Owned; Customer Funded Interconnection Facilities**

Element	Description	Cost Est. Millions
<b>Western's Ault 230 kV Substation</b>	Interconnect Customer at Western's Ault 230 kV Substation. The new equipment includes 230 kV bi-directional metering, Balancing Authority metering, relaying and associated equipment and materials.	<b>\$0.482</b>
	Transmission tie line into substation.	<b>\$0.232</b>
	Customer Generator Communication to Lookout.	<b>\$0.032</b>
	Customer LF/AGC and Generator Witness Testing.	<b>\$0.134</b>
	Siting and Land Rights for required easements, reports, permits and licenses.	<b>\$0.010</b>
	<b>Total Cost Estimate for Customer Interconnection Facilities</b>	<b>\$0.890</b>
<b>Time Frame</b>		<b>12 Months</b>

**Table 2: PSCo Interconnection Facilities**

Element	Description	Cost Est. Millions
<b>Western's Ault 230 kV Substation</b>	Interconnect Customer at Western's Ault 230 kV Substation. New 230 kV line termination requiring the following equipment: <ul style="list-style-type: none"> <li>• one 230 kV 40 kA, 3000 amp, circuit breaker</li> <li>• two 230 kV, 3000 amp gang switches</li> <li>• electrical bus work</li> <li>• required steel and foundations</li> <li>• minor site work (station wiring, grounding)</li> </ul>	<b>\$0.412</b>
<b>Time Frame</b>		<b>12 Months</b>

**Table 3 – PSCo Network Upgrades for Delivery**

<b>Element</b>	<b>Description</b>	<b>Cost Est. Millions</b>
<b>Western’s Ault 230 kV Substation</b>	New 230 kV line termination requiring the following equipment: <ul style="list-style-type: none"> <li>• two 230 kV 40 kA, 3000 amp, circuit breakers</li> <li>• four 230 kV, 3000 amp gang switches</li> <li>• electrical bus work</li> <li>• metering, control, relaying and testing</li> <li>• required steel and foundations</li> <li>• minor site work (grading, fencing, grounding)</li> </ul>	<b>\$0.850</b>
<b>PSCo’s Cherokee 230 kV Switching Station</b>	New 230 kV line termination requiring the following equipment: <ul style="list-style-type: none"> <li>• one 230 kV, 50 kA, 3000 amp circuit breaker</li> <li>• two 230 kV 3000 amp gang switches</li> <li>• electrical bus work</li> <li>• metering, control, relaying and testing</li> <li>• required steel and foundations</li> </ul>	<b>\$0.561</b>
<b>230 kV Transmission Line Construction</b>	New single circuit Ault –Ft. Lupton 230 kV line (59 miles) 800 MVA capacity, bundled 954 kcmil (Cardinal) conductor.	<b>\$27.630</b>
	Convert the existing 115 kV line from Ft. Lupton to Cherokee to double circuit 230 kV operation (800 MVA capacity). One circuit will connect to the new Ault 230 kV line just outside of Ft. Lupton and the other will be operated at 115 kV to serve the 115 kV substations along the way to Cherokee (29 miles).	<b>\$27.480</b>
<b>Siting and Permitting</b>	Obtain necessary siting, permits, easements and ROW as required.	<b>\$7.190</b>
	<b>Total Cost Estimate for PSCo Network Upgrades for Delivery</b>	<b>\$63.711</b>
	<b>Total Cost of Project</b>	<b>\$65.013</b>
<b>Time Frame</b>		<b>60 Months</b>

**Assumptions for Alternatives**

- Cost estimates provided are “scoping estimates” with an accuracy of +/- 30%.
- Estimates are based on 2008 dollars (no escalation applied).
- There is no contingency or AFUDC included in the estimates.
- Labor is estimated for straight time only – no overtime included.
- PSCo (or it’s Contractor) crews will perform all construction and wiring associated with PSCo owned and maintained facilities.

- The Wind Site is not in PSCo's service territory. The local utility will provide station service power to the generator. Assumed no additional metering is required.
- It is anticipated that in order to construct the PSCo network upgrades for delivery, a Certificate of Public Convenience and Necessity (CPCN) will be required by the Colorado Public Utilities Commission (CPUC). The application for a CPCN will not be submitted until the Interconnection Agreement is fully executed. The estimated time frame for the CPCN process, siting, permitting, easement and right-of-way acquisition, design and construction for the PSCo network upgrades is at least 60 months from the time the Interconnection Agreement is fully executed. This time frame is also based on other identified assumptions for Siting and Land Rights, Substation Engineering and Transmission Engineering as listed below.
- Implementation of the recommended infrastructure for delivery will require that existing facilities be taken out of service for sustained periods. In most cases, these outages cannot be taken during peak load periods due to operational constraints. As a result, the estimated time frame for implementation could be increased by 3-6 months.
- A siting study will be required if network upgrades for delivery. Extensive public involvement is anticipated. Permit applications and possible minor right-of-way acquisition will be required. Land use permits will be required from multiple local jurisdictions.
- No additional land will be required at Ault Substation and that there is room in the existing yard for the proposed additions and the two required line positions are available.
- Western<sup>7</sup> will be contacted to provide estimates at Ault for any additional studies.
- Western will construct and maintain all facilities at Ault.
- Schedules and equipment lead times have been taken into account.

---

<sup>7</sup> Western Area Power Administration – Rocky Mountain Region

# APPENDIX

## A. Power Flow Study Results

### 1. Energy Resource (ER) Evaluation

Energy Resource Interconnection Service (ER) is an Interconnection Service that allows the Interconnection Customer to connect its Generating Facility to the Transmission Provider's Transmission System to be eligible to deliver the Generating Facility's electric output using the existing firm or non-firm capacity of the Transmission Provider's Transmission System on an "as available" basis. Energy Resource Interconnection Service in and of itself does not convey transmission service.

The study determined that the Customer may interconnect as a Network Resource after the required Network Upgrades for Delivery are completed. Interconnection as an Energy Resource will require the same Network Upgrades to deliver the requested generation level on a firm basis. Some non-firm transmission capability may be available depending upon generation dispatch levels, demand levels, import path levels (TOT7, etc), and the operational status of transmission facilities

### 2. Network Resource (NR) Evaluation

The power flow analysis provided a preliminary identification of any thermal or voltage limit violations resulting from the interconnection, and for an NR scenario, a preliminary identification of network upgrades required to deliver the proposed generation to PSCo loads.

#### a. Study Criteria

PSCo adheres to NERC Reliability Standards<sup>8</sup> and WECC Criteria<sup>9</sup> as well as internal company criteria for planning studies. The following criteria are used for studies:

#### Category A – System Normal

"N-0" System Performance Under Normal (No Contingency) Conditions (Category A)

NERC Standard TPL-001-0

Voltage:	0.95 to 1.05 per unit
Line Loading:	100 percent of continuous rating
Transformer Loading:	100% of highest 65 °C rating

---

<sup>8</sup> Specifically NERC TPL-001-0 through 004-0 Standards

<sup>9</sup> April 2008 TPL – (001 thru 004) – WECC – 1 – CR – System Performance Criteria



Category B – Loss of generator, line, or transformer (Forced Outage)

“N-1” System Performance Following Loss of a Single Element (Category B)

NERC Standard TPL-002-0

Voltage:	0.90 to 1.10 per unit
Line Loading:	100 percent of continuous rating
Transformer Loading:	100% of highest 65 °C rating

**b. Wind Farm Model**

The wind farm would consist of 200 1.5-MW turbines for a total project output of 300 MW. The Wind Turbine used for the Project is the Acciona AW1500 Wind Turbine and each wind turbine is rated at 1.5 MW with a +0.93 to -0.93 power factor i.e. it can produce or absorb 0.59 MVAR. The Acciona wind turbine operates at a terminal voltage of 12 kV, which is then stepped up to 34.5 kV by a generator step up transformer installed at the base of the tower. The 34.5 kV output from the turbines is collected at the Project substation via underground feeder cables. Preliminary layout for the Collection System has been provided. As per the layout, the Collector System is comprised of 20 feeder circuits, with 10 turbines connected to each feeder. Except for one feeder circuit, all feeder circuits have been equivalenced for representation in PSS/E. One feeder circuit has been modeled with adequate detail to study the wind turbine behavior. The 34.5 kV bus at the substation is divided into two separate buses with 10 feeders on each bus. Two 34.5/230 kV transformers step up the wind farm output to the 230 kV level for interconnection to the PSCo system via a project-owned 35 mile 230 kV transmission line. The Point of Interconnection (POI) is at the Ault 230 kV bus.

The Wind Turbines are self-regulating the local generator bus to a 1.04 per unit voltage. Each 34.5/230 kV transformer controls the 34.5 kV side voltage, holding it at/under 1.02 per unit

**c. Interconnection Scenarios Studied**

The following interconnection scenarios were studied:

- Scenario 1 - Interconnection to the Ault 230 kV bus without system upgrades
- Scenario 2 - Interconnection to the Ault 230 kV bus with a new Ault–Cherokee 230 kV line
- Scenario 3 - Interconnection to the Ault 230 kV bus with a new Ault–Ft.Lupton–Cherokee 230 kV line

**d. Interconnection Study Results**

AC contingency analysis was performed using the PSS/E software called “Managing and Utilizing System Transmission (MUST)” to determine if interconnecting the project would result in overloads on the bulk transmission system. The results indicate that a new Ault–Cherokee 230 kV line mitigates most of the overloads and is the best scenario among the three studied.

**1. Scenario 1: Interconnecting at the Ault 230 kV bus with No Network Upgrades**

Scenario 1 that included the proposed 300 MW wind farm and a 35-mile transmission line from the wind farm to the Ault 230 kV bus, was modeled in the study case and the power scheduled to PSCo load. Facility outages were simulated and the results are listed in Table 4 below.

Table 4: Contingency Results for Scenario 1 (Wind Farm Interconnected at the Ault 230 kV bus)

** From bus	** ** To bus	** CKT	Branch Rating	Loading With GI-2007-3	Base Case Loading	Contingency
70191 FTLUPTON 115	70192 FTLUPTON 230	T3	280.0	280.4	270.7	70447 VALMONT 230 70592 SPNDLE 230 1
70192 FTLUPTON 230	70410 ST.VRAIN 230	1	435.0	522.4	473.2	70192 FTLUPTON 230 70410 ST.VRAIN 230 2
70192 FTLUPTON 230	70410 ST.VRAIN 230	2	435.0	522.4	473.2	70192 FTLUPTON 230 70410 ST.VRAIN 230 1
70192 FTLUPTON 230	70529 JLGREEN 230	1	495.0	516.8	489.9	70192 FTLUPTON 230 70605 HENRYLAK 230 1
70345 RALSTON1 115	70444 VALMONT 115	1	108.8	129.3	122.7	70447 VALMONT 230 70543 SIMMS 230 1
70395 SMOKYHIL 115	70521 PEAKVIEW 115	1	186.6	207.7	199.0	70396 SMOKYHIL 230 70551 MURPHY 230 1
70410 ST.VRAIN 230	70471 WELD PS 230	1	500.0	546.1	474.2	70474 WINDSOR 230 73011 AULT 230 1
70461 WASHINGT 230	70529 JLGREEN 230	1	495.0	499.1	472.2	70192 FTLUPTON 230 70605 HENRYLAK 230 1
70471 WELD PS 230	73212 WELD LM 230	1	637.0	670.2	595.2	70474 WINDSOR 230 73011 AULT 230 1
70474 WINDSOR 230	73011 AULT 230	1	495.0	495.2	438.4	70471 WELD PS 230 73212 WELD LM 230 1
70609 SILVSADL 230	70610 REUNION 230	1	326.0	345.2	333.9	70192 FTLUPTON 230 70529 JLGREEN 230 1
73008 ARCHER 115	73043 CHEYENNE 115	1	80.0	113.7	109.7	73008 ARCHER 115 73480 CROWCRK 115 1
73011 AULT 230	73212 WELD LM 230	1	478.0	498.1	452.1	73011 AULT 230 73212 WELD LM 230 2
73011 AULT 230	73212 WELD LM 230	2	478.0	498.1	452.1	73011 AULT 230 73212 WELD LM 230 1
73150 PEETZ 115	73191 STERLING 115	1	109.0	110.1	<109.0	73143 N.YUMA 230 73579 SPRNGCAN 230 1
73211 WELD LM 115	73212 WELD LM 230	1	150.0	237.3	220.7	70471 WELD PS 230 73212 WELD LM 230 1

The results show that the addition of the GI-2007-3 Project alone without network upgrades would result in significant increases in contingency flows (flow on a line after a outage of another line) of the transmission lines in the study area. For example, the 300 MW wind farm would cause contingency flows on either of the Ft.St.Vrain-Ft.Lupton 230 kV lines to increase from 473.2 MVA (109% of its 435 MVA rating) to 522.4 MW (120% of its 435 MVA rating). The Ft.Lupton-JL Green 230 kV contingency flow would increase from 489.9 MVA (99% of its 495 MVA rating) to 516.8 MVA (104% of its 495 MVA



rating). The Weld-Ft.St.Vrain 230 kV contingency flow would increase from 474.2 MVA (95% of its 500 MVA rating) to 546.1 MVA (109% of its 500 MVA rating). Western's Ault-WeldLM 230 kV lines would experience an increase in contingency flows with the contingency flow of either line increasing from 452.1 MVA (95% of its 478 MVA rating) to 498.1 MVA (104% of its 478 MVA rating). It is clear from these study results that network upgrades would be needed to allow the proposed 300 MW wind farm to be interconnected to the bulk transmission system to serve PSCo load.

## 2. Scenario 2: Interconnecting at the Ault 230 kV Bus with a New Ault-Cherokee 230 kV Line Added

Scenario 2 that included the proposed 300 MW wind farm, a 35-mile transmission line from the wind farm to the Ault 230 kV bus and a new Ault-Cherokee 230 kV line, was modeled in the study case and the power scheduled to PSCo load. Facility outages were simulated and the results are listed in Table 5 below.

Table 5: Contingency Results for Scenario 2 (Wind Farm Interconnection at the Ault 230 kV Bus with a new Ault-Cherokee 230 kV Line)

** From bus	** ** To bus	** CKT	Branch Rating	Loading With GI-2007-3 %	Base Case Loading %	Contingency
70108 CHEROKEE 115	70126 CONOCO 115	1	134.8	107.9 %	104.1 %	70108 CHEROKEE 115 70277 MAPLETO2 115 1
70138 DANIELPK 115	70139 DANIELPK 230	T1	150.0	115.4 %	114.9 %	70517 PARKERPS 115 70518 BAYOU 115 1
70395 SMOKYHIL 115	70521 PEAKVIEW 115	1	186.6	111.2 %	106.7 %	70396 SMOKYHIL 230 70551 MURPHY 230 1
73008 ARCHER 115	73043 CHEYENNE 115	1	80.0	147.4 %	137.1 %	73008 ARCHER 115 73480 CROWCRK 115 1
73008 ARCHER 115	73480 CROWCRK 115	1	121.7	101.8 %	95.1 %	73008 ARCHER 115 73043 CHEYENNE 115 1

The study results listed in Table 5 demonstrate that the addition of the new Ault-Cherokee 230 kV line mitigates the overloads listed in Table 4 above. The addition of the proposed Ault 300 MW Wind Facility and the Ault-Cherokee 230 kV line redistributes power flows in the Western and PSCo systems near Ault and Cherokee. For example, the Archer-Cheyenne 115kV line contingency flow increases from 137.1% to 147.4% due to the addition of the proposed 300 MW wind farm and line. This contingency overload is a pre-existing condition and was ignored. In contrast, the addition of the 300 MW wind generation facility and the Ault-Cherokee 230kV line causes the Archer-Crow Creek 115kV line overload to increase from 95.1% to 101.8%. Therefore, the proposed wind farm (even with the Ault-Cherokee 230kV line added) creates a new overload that was not present before the addition; therefore, this criteria violation needs to be addressed.

PSCo contacted Western about these contingency overloads. Western indicated that both of these lines were rerated in 2007 to 148.0 MVA. The new line capacities are well

above the contingency flows observed in the study case; therefore, no further action is required.

### **3. Scenario 3: Interconnecting at the Ault 230 kV Bus with a New Ault-Ft. Lupton-Cherokee 230 kV Line Added**

Scenario 3 was considered. It is identical to Scenario 2 except that the Ault-Cherokee 230 kV line was looped in-and-out of the Ft.Lupton 230 kV bus. Scenario 3 that included the proposed 300 MW wind farm, a 35-mile transmission line from the wind farm to the Ault 230 kV bus and a new Ault-Ft.Lupton-Cherokee 230 kV line, was modeled in the study case and the power scheduled to PSCo load. Facility outages were simulated and the results were evaluated. The studies show that looping the Ault-Cherokee 230 kV line in-and-out of Ft. Lupton does not provide further benefit over Scenario 2. The study concludes that a new Ault-Cherokee 230 kV line removes most of the overloads identified in Scenario 1. Therefore, Scenario 2 remains the preferred network upgrade and the stability study was conducted with the proposed Ault-Cherokee 230 kV line added to the study case.

#### **e. Wind Farm Reactive Power Capability**

This section presents the results of a study to examine the power factor (reactive power) requirements of a wind generating facility. PSCo has developed planning guidelines based on the following principles:

- Interconnecting to the PSCo bulk transmission system requires the Customer to adhere to certain interconnection requirements. Many of these requirements are contained in the Interconnection Guidelines for Transmission Interconnected Producer-Owned Generation Greater than 20 MW (Guidelines).
- The Interconnection Guidelines make reference to interconnection requirements resulting from FERC Order 661A. FERC Order 661A describes the interconnection requirements for wind generation plants.
- PSCo System Operations conducts commissioning tests prior to the commercial in-service date for a Customer's facilities.

The three principles listed above were developed into a list of guidelines. These guidelines are as follows:

1. A wind generating plant shall maintain a power factor within the range of 0.95 leading to 0.95 lagging, measured at the POI. The Transmission Provider's System Impact Study is needed to demonstrate that such a power factor requirement is necessary to ensure safety or reliability.

2. The voltage at a Point Of Interconnection shall be maintained in the ideal voltage range for the appropriate Colorado region and bus type (regulating<sup>10</sup> or non-regulating) as determined in the Rocky Mountain Area Voltage Coordination Guidelines<sup>11</sup>. The System Impact Study will investigate the pertinent demand (on-peak or off-peak), season (summer or winter), dispatch, and outage scenarios based on the defined study area that includes the proposed POI. The study will conform to the NERC Transmission System Planning Performance Requirements (TPL standards).
3. The POI for a wind generating facility should not be declared a regulating bus unless system studies demonstrate that the designation of the POI as a regulating bus is needed for system reliability or safety.
4. The impact of the wind generating facility on the reactive power schedules of nearby generation units may need to be mitigated by the Customer if system studies demonstrate that the proposed wind generating facility causes nearby generating units to generate or absorb reactive power for voltage control. It is understood that sufficient power reserve must be maintained on existing generating units to allow them to dynamically regulate voltage for extreme system conditions.
5. If a wind generating facility is interconnected to the bulk transmission system but is operating with its generation off-line and receiving power from the bulk transmission system for its station service requirements, that facility is acting as a load and will be required to maintain the power factor at the POI within 98% lagging or leading (when the station service load is greater than 85% of maximum) per the Xcel Energy document titled Interconnection Guidelines For Transmission Interconnected Customer Loads.
6. PSCo System Operations will require the Customer to perform operational tests prior to commercial operation that would verify that the equipment installed by the Customer meets operational requirements.
7. It is the responsibility of the Customer to determine what type of equipment (DVAR, added switched capacitors, SVC, reactors, etc.), the ratings (MVAR, voltage--34.5 kV or 230 kV), and the locations of those facilities that may be needed for acceptable performance during the commissioning testing.

---

<sup>10</sup> A regulating bus is defined in the Rocky Mountain Area Voltage Coordination Guidelines as any transmission or generation bus with controllable VAR's. This implies that the bus has a voltage schedule that is being regulated by a generating facility. Generating facilities include Static VAR Compensators (SVC's), synchronous generators, or synchronous condensers that can supply fast-acting reactive power (VAR) compensation to dynamically regulate voltage at a power system bus. Switchable capacitors, switchable reactors, load tap changing transformers, etc. are not defined as generating facilities as they do not provide controllable dynamic VARs'.

<sup>11</sup> The Voltage Coordination Guidelines Subcommittee (VCGS) of the Colorado Coordinated Planning Group developed the guidelines. The subcommittee consisted of representatives from major Colorado utilities including Colorado Springs Utilities, Platte River Power Authority, Tri-State Generation and Transmission, Public Service Company of Colorado, and Western Area Power Administration-Rocky Mountain Region. Other major utilities outside of Colorado were also involved in the development of these guidelines.

8. PSCo requires the Customer to provide a single point of contact to coordinate compliance with the power factor and voltage regulation at the POI. The reactive flow at the end of the line near the POI will need to be controlled according to the Interconnection Guidelines.

Item 1 makes reference to the wind generating plant maintaining a power factor within the range of 0.95 leading to 0.95 lagging, measured at the POI, if the Transmission Provider’s System Impact Study shows that such a requirement is necessary to ensure safety or reliability.

The System Impact Study examined the proposed 300 MW wind generation facility as it interconnects to the Ault 230 kV bus. The power flow studies show that the wind generation facility is within criteria when the wind farm is operating at full output. With the wind farm generating at a 300 MW maximum output, the Ault 230kV bus (POI) bus voltage is at 1.024 p.u., the customer’s facilities (line plus wind generation site) absorb 41.1 MVAR of reactive power, and the power factor is within the required 0.95 lagging/leading range (see Table 6 below). Based on the scenarios considered, the wind generating facility appears to operate within the 0.95 lagging and 0.95 leading power factor range with the voltages at the POI remaining within criteria<sup>12</sup> at full output

**Table 6: Wind Farm Reactive Power Capability Results**

	Ault 230kV Bus (POI) Voltage in per unit voltage	Reactive Power (MVAR) Delivered <sup>13</sup> to the Customer from the System at the Ault 230kV (POI)	Reactive Power Required at POI (MVAR)
Wind Farm with Wind Generating Units at Maximum Output (300 MW)	1.024	+ 41.10	0
Wind Farm with Wind Generating Units Off-line (0 MW)	1.018	- 26.30	26

Table 6 also demonstrates that with the Customer wind units off-line, the Ault 230kV bus (POI) voltage is at 1.018 p.u., and 26.3 MW is injected into the Ault 230kV bus

<sup>12</sup> . The Rocky Mountain Area Voltage Coordination Guidelines (that were developed by the Voltage Coordination Guidelines Subcommittee (VCGS) of the Colorado Coordinated Planning Group) indicate that system should be operated in such a way that Ault 230 kV bus voltage (regulated bus) in Foothills Area should remain within an ideal voltage range from 1.0 p.u and 1.04 p.u.

<sup>13</sup> The reactive power delivered to the Customer from the System at the Ault 230kV (POI) is defined as “+” when reactive power is flowing from the Ault 230kV bus to the Customer site and is defined as “-“ when power is flowing to the Ault 230kV bus from the Customer.



(POI) from Customer’s 230 kV transmission line. The voltage of 1.018 p.u. is within the voltage range of 1.00 p.u. to 1.04 p.u. for a controlled bus. However, the power factor under these conditions is 0.9 lagging, outside the required power factor range for loads. Therefore, approximately 26 MVAR of inductors would be needed to bring the power factor within the required range. The Ault Substation is owned by Western; therefore, the requirement to add 26 MVAR of reactors will need to be discussed with Western.

The study did not investigate all possible operating conditions including single circuit and double circuit outages. Further study work would be required to study the impact of the proposed wind generating facility on the power factor and voltage at the POI.

NOTE - It is the responsibility of the Customer to determine what type of equipment is required (CVAR, added switched capacitors, SVC, reactors, etc.) and at what final ratings (MVAR, voltage 34.5 kV, 230 kV) and location (Ault 230 kV POI) will be necessary to meet these reactive power controllability requirements. Furthermore, the actual voltage tap ratios used for the Customer’s main 230 - 34.5 kV transformers will directly impact the operating voltages and related reactive capabilities for the Ault wind generating facility. The Customer should review these issues in determining the final design requirements for this equipment (CVAR, transformer voltage tap ratios and MVA, etc.).

## B. Short Circuit Study Results

A short circuit study was conducted to determine the fault currents (single-line-to ground or three-phase) at the Ault Substation after the addition of the proposed Ault 300 MW Wind Farm and the Ault-Cherokee 230 kV transmission line. The short circuit study determined the fault levels at the Ault 230 kV bus with the proposed Ault-Cherokee 230 kV transmission line added.

Table 7 Short-Circuit Study Results With the Proposed Ault-Cherokee 230 kV Line

System Condition	Three-phase (amps)	Thevenin System Equivalent Impedance (R,X) (ohms)	Single-line-to-ground (amps)	Thevenin System Equivalent Impedance (R,X) (ohms)
System Intact with the Proposed Ault-Cherokee 230 kV Line Added	I <sub>1</sub> =24,682.4 I <sub>2</sub> =I <sub>0</sub> =0 I <sub>A</sub> =I <sub>B</sub> =I <sub>C</sub> =24,682.4	Z <sub>1</sub> (pos)= 0.44479,5.36155 Z <sub>2</sub> (neg)=0.45032,5.36313 Z <sub>0</sub> (zero)=0.69030,5.42267	I <sub>1</sub> =I <sub>2</sub> =8,184.3 I <sub>0</sub> =24,553.0 I <sub>B</sub> =I <sub>C</sub> =0 I <sub>A</sub> =24,553.0	Z <sub>1</sub> (pos)= 0.44479,5.36155 Z <sub>2</sub> (neg)=0.45032,5.36313 Z <sub>0</sub> (zero)=0.69030,5.42267

PSCo will share the study results with Western so that Western can verify that the proposed Ault 300 MW Wind Farm and the Ault-Cherokee 230 kV line addition will not necessitate the replacement of circuit breakers, switches or other substation equipment due to the increased fault current levels.

## **C. Dynamics Stability Analysis Study Results**

Transient stability analyses for system intact initial conditions are performed at the appropriate dispatch and demand scenario(s). The NERC Standards for transient stability criteria require that all machines remain in synchronism, all voltage swings should be damped. In addition, the WECC Criteria for and voltage/frequency performance must meet the following performance criteria:

- Following fault clearing for single contingencies, voltage on load buses may not dip more than 25% of the pre-fault voltage or dip more than 20% of the pre-fault voltage for more than 20 cycles.
- For double contingencies (i.e., breaker failures), voltage on load buses may not dip more than 30% of the pre-fault voltage or dip more than 20% of the pre-fault voltage for more than 40 cycles.

### **1. Study Data**

The benchmark stability analysis started from a WECC-approved 2011HS power flow base case, with the associated machine model data for the 2011 summer peak period. This case has been used in recent stability analyses for several other generator system impact studies. Generation from the new project is assumed to displace generation from the existing Comanche units. The Acciona AW1500 Wind Turbine model was developed for use with PSS<sup>TM</sup>E version 30.0 and hence is not compatible with version 30.2. Consequently, the base case scenario was studied using PSS<sup>TM</sup>E version 30.2 whereas the new generation scenario was studied using PSS<sup>TM</sup>E version 30.0.

### **2. Methodology**

Initially, the stability analysis was performed for the benchmark case. After reviewing the data for reasonableness and obtaining a flat start with the benchmark case, dynamic simulations were performed for both the benchmark case and the case with the new wind generation (GI-2007-3) for a common set of system disturbances to determine if the addition of the new wind generation would have any adverse impacts on the system.

Rotor angles, mechanical and electrical power, generator terminal voltages, and frequency were monitored for representative generating units throughout control areas 70 and 73. In addition, voltages at the 115 kV, 230 kV, and 345 kV buses in areas 70 and 73 were also monitored.

### **3. Study Criteria**

WECC planning criteria including voltage deviation criteria for system response after disturbances was used in the analysis. Specifically, WECC requires that for a single contingency, transient voltage dips cannot exceed 25% at load buses, or 30% at non-load buses, cannot exceed 20% for more than 20 cycles at any load bus, cannot have a post-transient voltage deviation exceed 5% at any bus, and the frequency cannot dip below 59.6 Hz for 6 cycles or more at a load bus. For multiple contingencies, transient voltage dips cannot exceed 30% at any bus and cannot exceed 20% for more than 40 cycles at any load bus, cannot have a post-transient voltage deviation exceed 10% at any bus, and frequency cannot dip below 59.0 Hz for 6 cycles or more at a load bus. The addition of any new generation cannot produce a system performance that is out of compliance with the values stated above.

### **4. Disturbance Scenarios**

A list of faults near the proposed GI-2007-3 Project were developed that should provide a reasonably thorough evaluation of system performance (see Tables 8, 9, and 10). Fifteen three-phase faults on single 230 kV or 345 kV circuits were studied, with fault clearing in 5 cycles, for 230 kV, or 4 cycles, for 345 kV. In addition, five three-phase faults were studied that required the tripping of two circuits in 5 cycles. Finally seven contingencies were studied that consisted of single-line-to-ground faults due to breaker failure with delayed backup clearing, at 16 cycles.

### **5. Results**

For all contingencies that were studied, the results of the stability analysis indicate that the addition of Scenario 2 (a 300 MW Wind Farm connected to the Ault 230 kV bus along with an Ault-Cherokee 230kV line) does not have an adverse impact on the response of the system to severe system disturbances. All generation remained on line, except where disconnected from the system. All oscillations were positively damped and voltage deviations on nearby 115 kV and 230 kV buses were well within criteria. The contingencies consisting of delayed clearing were similarly behaved with no undamped oscillations and voltage response within criteria as well. Results of system behavior in the benchmark case were similar to those observed for the case with GI-2007-3 generation.

For the single-line-to-ground with delayed clearing faults, it was observed that the Acciona Wind Turbine voltages are marked by oscillations (choppiness) that remain throughout the duration of the fault. These oscillations are also reflected on to the 230 kV side, though not significantly. However, after the fault is cleared the voltages recover to the initial condition and the system is stable. It is recommended that further



investigation into the Acciona Wind Turbine model be carried out to understand the turbine's behavior and the resulting oscillations during a fault.

Table 8: List of (N-1) Bus Faults Used in Dynamics Study

Fault				Cleared Circuit 1						
Location			Duration	Bus 1			Bus 2			
Name	KV	Number	(Cycles)	Name	kV	Number	Name	kV	Number	Circuit
Ault	230	73011		4Ault	230	73011	Ault	345	73012	3
Ault	345	73012		4Ault	345	73012	LRS	345	73108	1
Ault	230	73011		5Ault	230	73011	Rawhide	230	73165	1
Rawhide	230	73165		5Rawhide	230	73165	Timberln	230	73199	1
Ault	230	73011		5Ault	230	73011	Timberln	230	73199	1
Ault	230	73011		5Ault	230	73011	Weld	230	73212	1
Cheyenne	230	73536		5Cheyenne	230	73536	SnowyRng	230	73571	1
Ault	230	73011		5Ault	230	73011	Archer	230	73009	1
Ault	230	73011		5Ault	230	73011	Windsor	230	70474	1
LRS	345	73108		4LRS	345	73108	Ault	345	73012	1
Rawhide	230	73165		5Rawhide	230	73165	Ault	230	73011	1
Archer	230	73009		5Archer	230	73009	Ault	230	73011	1
Ault	230	73011		5Ault	230	73011	Cherokee	230	70107	1
Ault	230	73011		5Ault	230	73011	Nwreactive	230	70667	1
NewWind	230	70651		5NewWind	230	70651	New34_2	35	70666	2

Table 9: List of (N-2) Bus Faults Used in Dynamics Study

Fault				Cleared Circuit 1							Cleared Circuit 2 (Due to Common Tower)						
Location			Duration	Bus 1			Bus 2			Ckt	Bus 1			Bus 2			Ckt
Name	kV	Number	(Cycles)	Name	kV	Number	Name	kV	Number		Name	kV	Number	Name	kV	Number	
Raw hide	230	73165	5	Raw hide	230	73165	Timberln	230	73199	1	Raw hide	230	73165	Ault	230	73011	1
Ault	230	73011	5	Ault	230	73011	Timberln	230	73199	1	Ault	230	73011	St. Vrain	230	70410	1
Ault	230	73011	5	Ault	230	73011	Weld	230	73212	1	Ault	230	73011	Weld	230	73212	2
Ault	230	73011	5	Ault	230	73011	Windsor	230	70474	1	Ault	115	73552	Nunn	115	73145	1
Ault	230	73011	5	Ault	230	73011	Archer	230	73008	1	Ault	115	73552	Cheyenne	115	73043	1

Table 10: List of Single Line-Ground Bus Faults with delayed clearing Used in Dynamics Study

Fault				Comment	Cleared Circuit 1							Cleared Circuit 2 (Due to Breaker Failure)							
Location			Duration		Bus 1			Bus 2			Ckt	Duration	Bus 1			Bus 2			Ckt
Name	kV	Number	(Cycles)		Name	kV	Number	Name	kV	Number		Cycles	Name	kV	Number	Name	kV	Number	
Ault	345	73012	4	Ault End of Ault-Craig Line	Ault	345	73012	Craig	345	79014	1	15	Ault	345	73012	Ault	230	73011	3
Ault	230	73011	5	Ault End of Ault-Archer Line	Ault	230	73011	Archer	230	73008	1	16	Ault	345	73012	Ault	230	73011	1
Ault	230	73011	5	Ault End of Ault-Weld #1 Line	Ault	230	73011	Weld	230	73212	1	16	Ault	345	73012	Ault	230	73011	3
Ault	230	73011	5	Ault End of Ault Weld #2 Line	Ault	230	73011	Weld	230	73212	2	16	Ault	230	73011	Raw hide	230	73165	1
Ault	230	73011	5	Ault End of Ault-Raw hide	Ault	230	73011	Raw hide	230	73165	1	16	Ault	230	73011	Weld	230	73212	2
Ault	230	73011	5	Ault End of Ault-FSV Line	Ault	230	73011	St. Vrain	230	70410	1	16	Ault	230	73011	Timberln	230	73199	1
Ault	230	73011	5	Ault End of Ault-Timberline	Ault	230	73011	Timberln	230	73199	1	16	Ault	230	73011	St. Vrain	230	70410	1



## **D. Ault Substation Proposed One-Line**

A revised one-line diagram of the Ault Substation after the addition of the proposed Ault-Cherokee 230 kV Transmission Line is shown below.



## **E. Schedule**

A generic schedule that represents the estimated time frame for the CPCN process, siting, permitting, easement and right-of-way acquisition, design and construction for the PSCo network upgrades is shown below.

# GI-2007-3 (SIS Report)

## 300 MW Wind Generation Interconnecting at Ault Substation

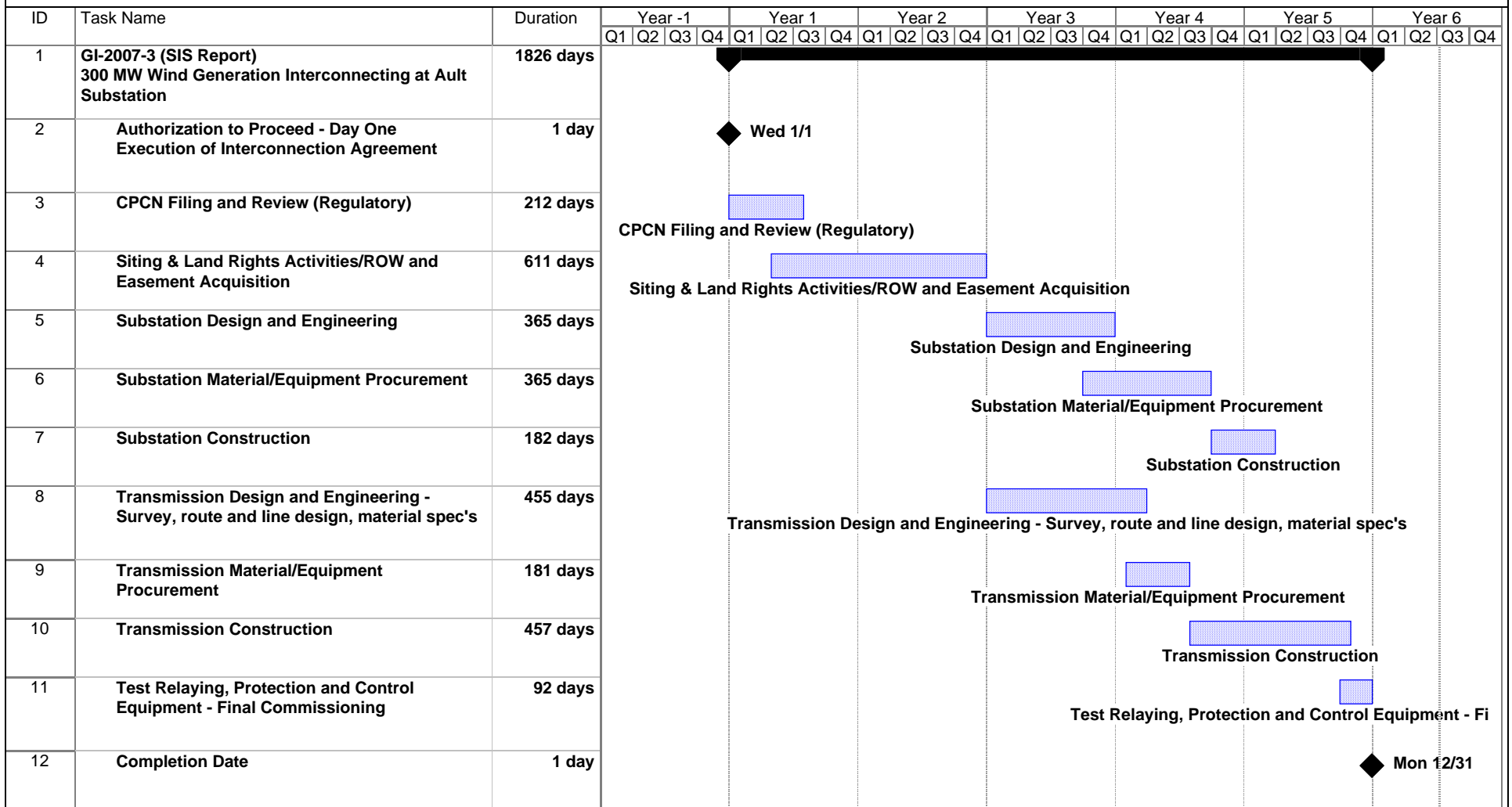

Project: Schedule 7-7-08.mpp Date: Mon 7/7/08	Task		Rolled Up Task		External Tasks	
	Progress		Rolled Up Milestone		Project Summary	
	Milestone		Rolled Up Progress		Group By Summary	
	Summary		Split			