

Interconnection Feasibility Study Report Request # GI-2006-4

200 MW Wind Expansion of Peetz Logan, near Peetz, Colorado

Xcel Energy Transmission Planning
April 20, 2007

Executive Summary

PSCo Transmission received a generation request to determine the feasibility of interconnecting 200 MW of new Customer wind turbine generation into the PSCo transmission system at the Pawnee Station 230 kV bus. The Customer proposed commercial operation date is October 1, 2008 with a back feed date of April 1, 2008. This request was studied as both an Energy Resource (ER)¹ and a Network Resource (NR)². The request was studied as a stand-alone project and considering other projects in the PSCo Generation Request queue³ specifically, GI-2006-1, GI-2006-2 and GI-2006-3.

Stand Alone Results

Energy Resource:

The ER portion of this study determined that the Customer could provide 50 MW of firm energy without the construction of network reinforcements. This determination is based on existing limitations due to the limitation on the lines out of Pawnee. Non-firm transmission capability may be available depending on marketing activities, dispatch patterns, demand levels and the status of transmission facilities.

Network Resource:

As a NR request, PSCo evaluated the network to determine the upgrades required to deliver the full 200 MW of wind generation to PSCo native load customers. Two alternatives have been recommended.

Alternative 1

¹ **Energy Resource Interconnection Service (ER Interconnection Service)** shall mean an Interconnection Service that allows the Interconnection Customer to connect its Generating Facility to the Transmission Provider's Transmission System to be eligible to deliver the Generating Facility's electric output using the existing firm or nonfirm capacity of the Transmission Provider's Transmission System on an as available basis. Energy Resource Interconnection Service in and of itself does not convey transmission service.

² **Network Resource Interconnection Service** shall mean an Interconnection Service that allows the Interconnection Customer to integrate its Large Generating Facility with the Transmission Provider's Transmission System (1) in a manner comparable to that in which the Transmission Provider integrates its generating facilities to serve native load customers; or (2) in an RTO or ISO with market based congestion management, in the same manner as all other Network Resources. Network Resource Interconnection Service in and of itself does not convey transmission service.

³ http://www.rmao.com/wtpp/psco_studies.html

The total estimated cost of the recommended system upgrades to accommodate the project for Alternative 1 is approximately **\$88.25** million and includes:

- \$ 0.04 million for PSCo-Owned, Customer Funded Interconnection Facilities
- \$0 million for PSCo Network Upgrades for Interconnection
- \$87.21 million for PSCo Network Upgrades for Delivery

These basic upgrades including interconnection as shown in Figure 1 would consist of:

- Constructing a new 115-mile 345 kV line from Pawnee to Daniels Park Substation. The new transmission can be described in three sections:
 - The first section consists of 80-miles of new 345 kV single circuit steel structures in new right of way from Pawnee and then join the existing PSCo transmission corridor near Brick Center Substation
 - Replace 15-miles of an existing single circuit line between Brick Center and Smoky Hill (part of the Pawnee-Daniels Park 230 kV line) with double circuit 345 kV capable structures. One side will operate at 230 kV to maintain the existing circuit. The other side will operate at 345 kV and make up the second section.
 - The final (third) section consists of constructing 20 miles of new 345 kV transmission from Smoky Hill to Daniels Park.
- Two 345/230 kV autotransformers at Pawnee
- One new 345 kV line termination at Daniels Park

A partial one-line of Pawnee Station can be found in Figure 2 detailing the interconnection.

There will not be any upgrades required for interconnection since the Customer is using its existing interconnection.

The estimated time required to engineer, permit, and construct the 345 kV transmission expansion for the Network Upgrade facilities for delivery is at least **60 months**; therefore, it is not feasible to construct the Network Upgrades for full Firm Delivery of this project before the required in-service date.

Additional details of the studies can be found under the Power Flow Study Results and in the appendix.

This study utilizes the existing Point of Interconnection (POI) for GI-2006-1(g) and the proposed GI-2006-2 at Pawnee Substation and the associated 72-mile 230 kV transmission line to deliver wind generation from this proposed expansion.

Figure 1: Recommended Network Upgrades For GI-2006-4.

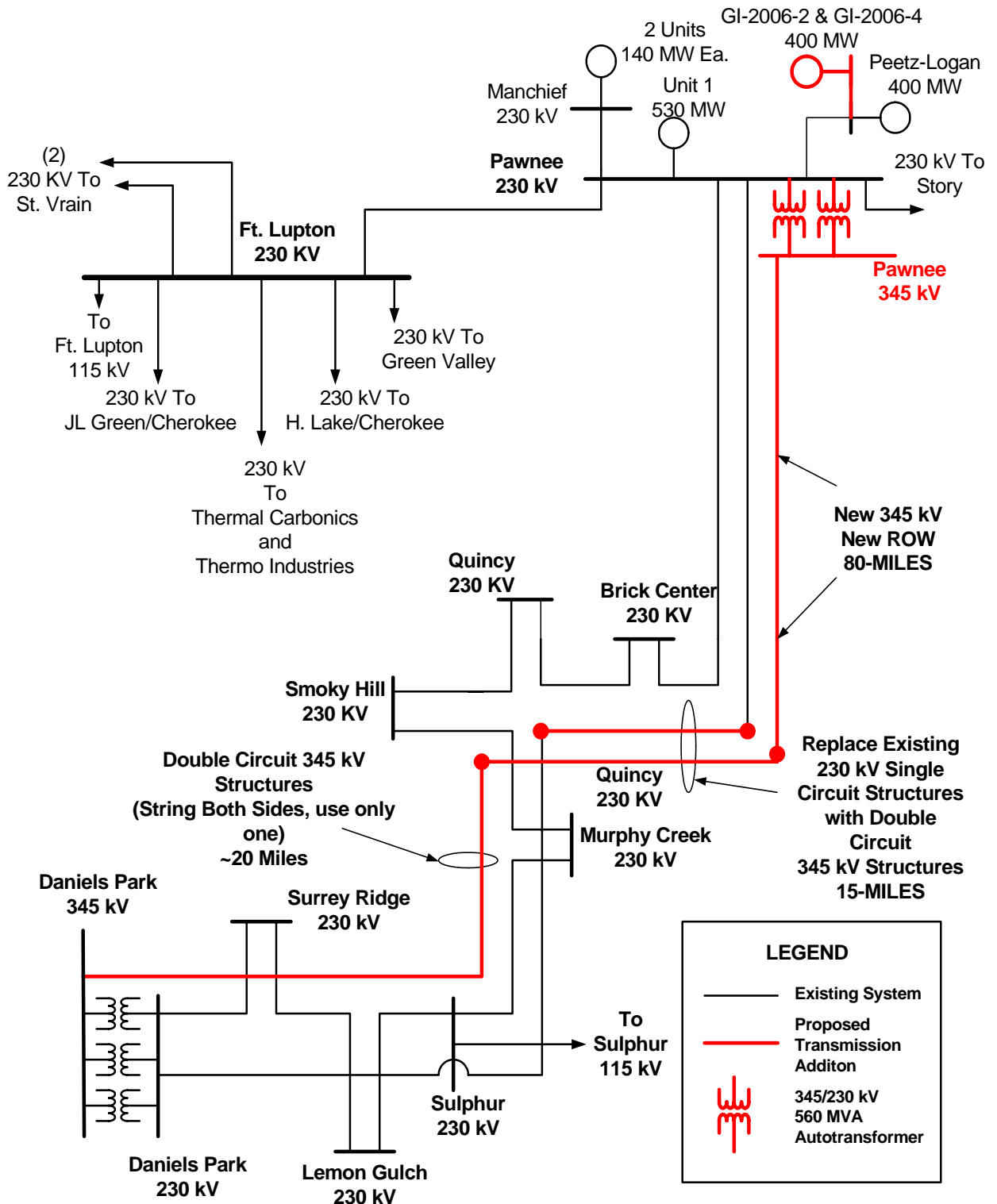
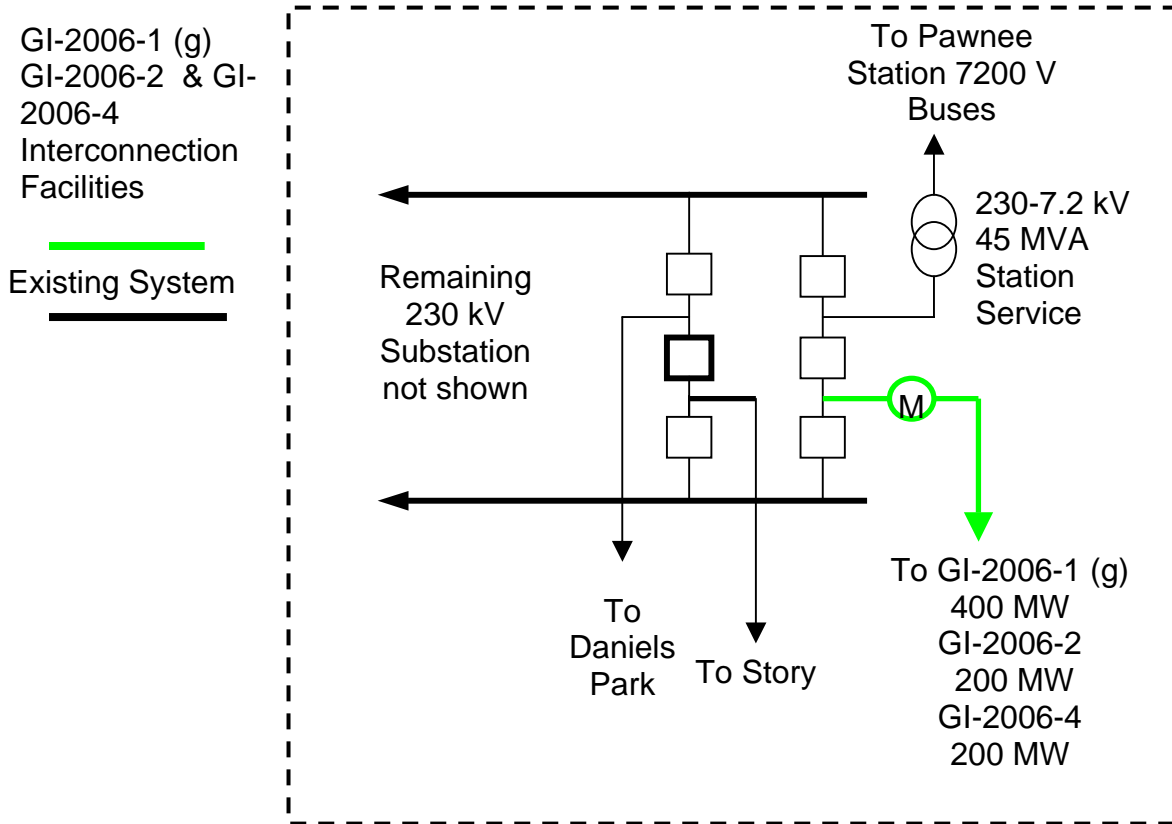

Figure 2: Simple Diagram of the Pawnee Interconnection



Alternative 2

The total estimated cost of the recommended system upgrades to accommodate the project for Alternative 2 is approximately **\$103.07** million and includes:

- \$ 0.04 million for PSCo-Owned, Customer Funded Interconnection Facilities
- \$0 million for PSCo Network Upgrades for Interconnection
- \$103.03 million for PSCo Network Upgrades for Delivery

These basic upgrades including interconnection as shown in Figure 3 would consist of:

- Converting the existing 115-mile 230 kV line from Pawnee to Daniel Park Substation from 230 kV operation to 345 kV operation and converting the existing 80-mile 230 kV line from Pawnee to Brick Center Substation from 230 kV operation to 345 kV operation. This can be described in four sections:
 - The first section would re-insulate and reconductor 80 miles of the existing Pawnee to Brick Center 230 kV line and the parallel Pawnee to Daniels Park 230 kV line for 345 kV operation.
 - The second section would require rebuilding 15-miles of single circuit wood structures with double circuit 345 kV structures from Brick Center to

just outside of Smoky Hill that currently make up the a portion of the Pawnee-Daniels Park 230 kV line.

- The third section would require rebuilding 15-miles of single circuit wood structures with double circuit 345 kV structures operated at 230 kV from Brick Center to just outside of Smoky Hill that currently make up the a portion of the Brick Center to Quincy/Smoky Hill 230 kV line. One circuit to continue on to Smoky Hill and the other to connect to the current double circuit structure that hold the existing Pawnee-Daniels Park 230 kV line making a Brick Center to Daniels Park 230 kV line
 - The fourth and final section requires constructing 20 miles of new double circuit 345 kV structures from just outside of Smoky Hill to Daniels Park utilizing the existing vacant corridor.
- Three 345/230 kV autotransformers at Pawnee
 - Two 345/230 kV autotransformers at Brick Center and associated 230 kV yard expansion.
 - Two 345 kV line terminations at Brick Center
 - One New 230 kV line termination at Brick Center
 - Two New 345 kV line terminations at Daniels Park

The Interconnection requirements for Alternate 2 would be the same as Figure 2.

The estimated time required to engineer, permit, and construct the 345 kV transmission expansion for the Network Upgrade facilities for delivery is at least **60 months**; therefore, it is not feasible to construct the Network Upgrades for full Firm Delivery of this project before the required in-service date.

Considering Other Requests (GI-2006-1, GI-2006-2 & GI2006-3)

The PSCo system can accept the full output of GI-2006-4 with either alternative #1 or #2. When considering other requests in the PSCo Generation Interconnection Request Queue specifically GI-2006-1, GI-2006-2 and GI-2006-3 and the Network Upgrades required for full delivery of these projects, no additional upgrades are required

Additional details of the studies can be found under the Power Flow section.

Figure 3 Alternative 2 Transmission Network with Recommended Upgrades for Delivery

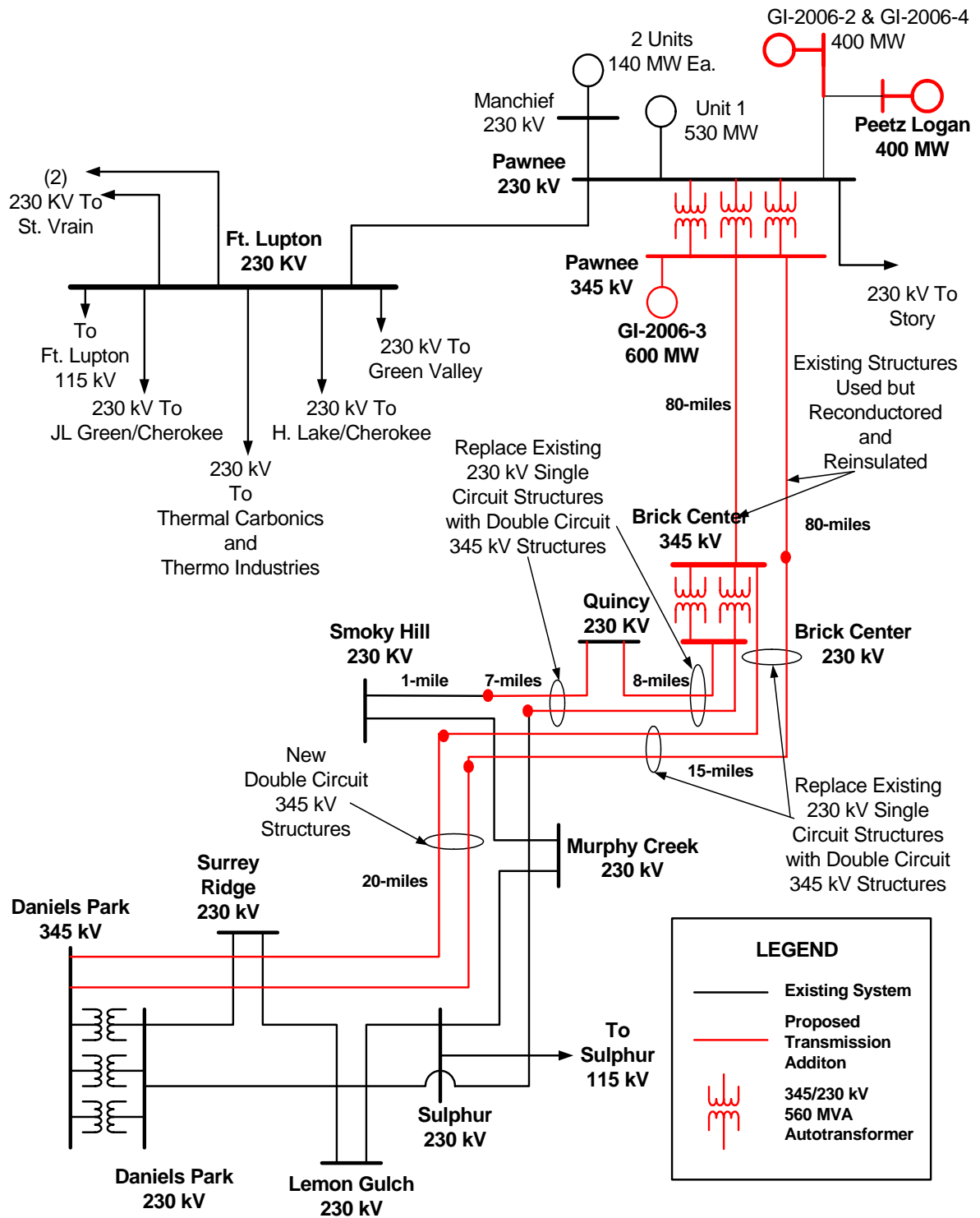

The execution of any Interconnection Agreement (IA) requires that certain conditions be met, as follows:

1. The conditions of the Interconnection Guidelines⁴ are met.
2. A single point of contact is given to Operations to manage the Transmission System reliably for all wind projects (GI-2006-1(g), GI-2006-2 and GI-2006-4).
3. Customer must show the ability to control power factor and voltage at the POI.
 - a. These studies indicated that the current Customer's transmission line design at full wind output (800 MW) does not meet the voltage and power factor requirements.
 - i. A light spring case shows a significant voltage drop at the POI.
 - ii. A heavy summer case shows that wind farm is not able to control the power factor at the POI.
 - b. The customer needs to determine a solution to the generators or transmission line to meet the voltage and power factor guidelines described in the Interconnection guidelines.

Introduction

PSCo Transmission received a large generator interconnection request (GI-2006-4) to interconnect one hundred thirty-three 1.5 MW, GE model SLE doubly fed induction generator (DFIG) wind turbines, for a total of 200 MW generation, with a commercial operation date of October 1, 2008 and a back feed date of April 1, 2008. The proposed wind farm (Project) would be located near Peetz, Colorado and would interconnect into the PSCo transmission system via the planned Customer 72-mile radial 230 kV line terminating at the PSCo Pawnee Station. This line is under construction and is part of GI-2006-1 (g) interconnection and the proposed GI-2006-2 200 MW expansion project. GI-2006-1(g) has an in-service date of October 1, 2007. The Customer has requested that this Project be evaluated as a Network Resource (NR) and an Energy Resource (ER) with the energy going to PSCo customers.

Study Scope and Analysis

The Interconnection Feasibility Study evaluated the transmission requirements associated with the proposed interconnection to the PSCo Transmission System. It consisted of power flow and short circuit analyses. The power flow analysis provided a preliminary identification of any thermal or voltage limit violations resulting for the interconnection, and for a NR request, a preliminary identification of network upgrades required to deliver the proposed generation to PSCo loads. The short circuit analysis identified any circuit breaker short circuit capability limits exceeded as a result of the Interconnection and for a NR request, the delivery of the proposed generation to PSCo loads.

⁴ Interconnection Guidelines for Transmission Interconnected Producer-Owned Generation Greater than 20 MW, version 3.0 12/31/06.

PSCo adheres to NERC / WECC Reliability Criteria, as well as internal Company criteria for planning studies. During system intact conditions, criteria are to maintain transmission system bus voltages between 0.95 and 1.05 per-unit of system nominal / normal conditions, and steady state power flows within 1.0 per-unit of all elements' thermal (continuous current or MVA) ratings. Operationally, PSCo tries to maintain a transmission system voltage profile ranging from 1.02 per-unit or higher at generation buses, to 1.0 per-unit or higher at transmission load buses. Following a single contingency element outage, transmission system steady state bus voltages must remain within 0.90 per-unit to 1.10 per-unit, and power flows within 1.0 per-unit of the elements continuous thermal ratings.

Based on the results of other generator interconnection studies, impacts to TOT3 and the neighboring utilities are considered minimal. For this project, affected parties include Western Area Power Administration (WAPA), and Tri-State Generation and Transmission (TSGT). These parties will receive a copy of this system impact study report.

Power Flow Study Models

The power flow studies were based on a PSCo developed 2010 heavy summer base case that originated from the Western Electricity Coordinating Council (WECC) 2011 heavy summer base model. The 200 MW wind farm was modeled as one 200 MW conventional generator with a 0.95 per unit (p.u.) lagging power factor (overexcited) and a 0.95 p.u. leading power factor (under-excited) capability to simulate the VAR capabilities of the generators, which the Customer has stated to be the GE 1.5 MW model SLE Double Fed Induction Generator. The project generation was scheduled to the southern PSCo system by reducing generation in that area.

The power flow studies were also based on a PSCo developed 2013 heavy summer base.

Pertinent modeling adjustments:

- o Other generation at Pawnee was modeled at full output, which included GI-2006-1, GI-2006-2 and GI-2006-3, or approximately 1,000 MW.
- o Study models included a planned upgrade of the existing Pawnee to Smoky Hill and Pawnee to Daniels Park 230 kV line to 637 MVA. These upgrades are projected to be complete in 2008.
- o Network upgrades for GI-2006-1 and GI-2006-3 were implemented in the power flow models.

The Point of Interconnection (POI) between the Customer and PSCo is assumed to be the point at which the Customer's 72-mile 230 kV transmission line connects to the

Pawnee Substation bus. The 72-mile line was modeled per the Customer provided information:

- A single-circuit 72-mile, 230 kV line using a combination conventional 230 kV “H-frame” wood pole and single steel pole construction with a two conductor bundled 795 ACSR per phase, with a 800 MVA rating.
- One 230-34.5 kV, 133/177/222 MVA Customer GSU transformer, located at the Customer collector site.

To evaluate the capabilities and system requirements for firm transfer levels, the powerflow model was modified to simulate TOT3 path flows at approximately 1,320 MW. Efforts were made to include in the models all transmission projects expected to be in service for the 2010 heavy summer season. The studies assumed 2010 peak summer demand conditions in the PSCo system and in other utility systems.

Power Flow Study Results and Conclusions

Energy Resource (ER) Study Results

The ER portion of this study determined that the Customer could provide 50 MW of firm energy without the construction of network reinforcements. This determination is based on existing limitations due to the limitation on the lines out of Pawnee. Non-firm transmission capability may be available depending on marketing activities, dispatch patterns, demand levels and the status of transmission facilities.

Network Resource (NR) Study Results

The NR study determined the network upgrades that would be required to accept the full 200 MW from the proposed generating plant for the conditions studied. At 200 MW of generation from the Customer, there were a number of contingency overloads. Appendix A shows the most significant contingencies and the associated overloads along with results from the benchmark case and with the Network Upgrades.

Studies indicated that if either of the proposed alternatives for Network Upgrades for Delivery are implemented for this project, there are no significant impacts to the neighboring utilities or to the TOT 3 transmission path.

Regional Transmission System

Studies show that the WAPA Beaver Creek area shows some potential of overloads under contingency scenarios. However, after coordinating with WAPA Transmission Planning it was discovered that a particular project in the Beaver Creek 230 kV

expansion⁵ plan was not modeled in the power flow. After incorporating the project in this study, all contingency overloads are mitigated.

Similarly, Intermountain Rural Electric Association (IREA) has several projects⁶ including new 115 kV Transmission in the region that has significant benefits to the regional transmission system. After modeling the proposed IREA projects, all regional contingency overloads are significantly reduced.

Voltage Control at the Point of Interconnection

Studies show that the 200 MW expansion project under certain conditions cannot meet the interconnection guidelines as mandated by PSCo in their Interconnection Guidelines for Transmission Interconnected Producer-Owned Generation Greater than 20 MW (Guidelines). In addition, studies show that during high levels of wind generation (300 MW or greater) the 230 kV line from the Wind Farm to the POI is absorbing excessive reactive power from existing system connected to the Pawnee 230 kV bus. This is an unacceptable operating condition. The Customer needs to demonstrate that the Guidelines are met. In addition, PSCo requires that the Customer provide a single point of contact⁷ to coordinate compliance with the power factor/voltage regulation at the POI. The Customer will need to control the VAR flow on their line according to the Interconnection Guidelines.

Short Circuit Study Results

The short circuit study results show that the fault current levels for all buses studied are within the interrupting ratings of the breakers; therefore, the Project and associated infrastructure will not cause fault current to exceed the circuit breaker ratings.

The faults currents at Pawnee are 22,792 Amps for a single-line to ground fault and 19,859 Amps for a three-phase fault. These values assume little to no fault current contribution from the proposed wind facility.

Costs Estimates and Assumptions

Alternative 1

The estimated total cost for the required upgrades is **\$87,250,000**.

The estimated costs shown are (+/-30%) estimates in 2007 dollars and are based upon typical construction costs for previously performed similar construction. These

⁵ This project consists of an overhead 230 kV Tie between the Story and the expanded Beaver Creek 230 kV WAPA Substations.

⁶ Projects include a 115 kV transmission line from Strasburg to Kiowa in 2010-11 time frame that unloads the Smoky Hill region.

⁷ The POI will provide a point of injection of wind generation from several different entities.

estimated costs include all applicable labor and overheads associated with the engineering, design, and construction of these new PSCo facilities. This estimate did not include the cost for any other Customer owned equipment and associated design and engineering.

The following tables list the improvements required to accommodate the interconnection and the delivery of the Project. The cost responsibilities associated with these facilities shall be handled as per current FERC guidelines. System improvements are subject to change upon more detailed analysis.

Since this project intends to use the interconnection from the 600 MW Wind Facilities GI-2006-1(g) and GI-2006-2 at Pawnee Station, there will be only minimal costs of \$38,400 associated with the interconnection required for this 200 MW expansion project GI-2006-4.

Table 1: Transmission Provider Interconnection Facilities (Customer Funded)

| Substation | Description | Cost |
|---|--|-----------------|
| Pawnee 230kV Switchyard | Interconnect Customer's 230kV line to the existing Pawnee Switchyard. The major work required includes: <ul style="list-style-type: none"> • Engineering and design • Transmission line relaying and testing | \$23,000 |
| Lookout Operations Center | Add additional status/weather monitoring points for the Customer's generation at Lookout Operations Center. The major work required includes: <ul style="list-style-type: none"> • Programming and wiring changes | 15,400 |
| Total Estimated Cost for PSCo Interconnection Facilities | | \$38,400 |
| Time Frame | | 3 Months |

Table 2: PSCo Network Upgrades for Delivery Alternative 1

| Element | Description | Cost Millions |
|-----------------------|--|----------------|
| Pawnee Station | Upgrades and modifications required at Pawnee Switchyard for adding a 345 kV yard. The major equipment required includes: <ul style="list-style-type: none"> • Four 345 kV 40 kA Circuit Breakers • Ten 345 kV Gang Switches • Two 345/230 kV 560 MVA autotransformers • Four 230 kV 40 kA, 3000 A, Circuit Breakers • Eight 230 kV Gang Switches • Transmission line relaying and testing • Site Expansion | \$13.41 |

| Element | Description | Cost Millions |
|--|--|------------------|
| Daniels Park Substation | 345 kV Line Termination equipment that includes: <ul style="list-style-type: none"> • Two 345 kV 40 kA Circuit Breakers • Four 345 kV Gang Switches • Transmission line relaying and testing | \$1.76 |
| Lookout Center | Energy Management System (EMS) Changes | \$0.09 |
| Pawnee – Daniels Park 345 kV line | Add a new single circuit 345 kV line from Pawnee -Daniels Park. This includes: <ul style="list-style-type: none"> • Single Circuit 345 kV from Pawnee to just outside of Brick Center Switching Station including new ROW (80 –Miles). • Rebuild existing Pawnee-Daniels Park single circuit 230 kV line from Brick Center to outside of Smoky Hill (15-miles) to double circuit 345 kV line One side operated at 345 and the other operated at 230 kV for the Pawnee-Daniels Park line. • Construct new double circuit 345 kV line from just outside of Smoky Hill to Daniels Park utilizing existing ROW (20-miles). String both sides of double circuit tower. | \$65.48 |
| Pawnee-Daniels Park 230 kV Line | Removal of Brick Center to Smoky Hill Section (15 Miles) | \$1.01 |
| | Siting and Land Rights land acquisition & permitting for all above | \$5.46 |
| | Total Estimated Cost for PSCo Delivery Infrastructure Upgrades | \$87.21 |
| Time Frame | | 60 Months |
| | TOTAL PROJECT COST | \$87.25 |

Alternative 2

The estimated total cost for the required upgrades for Alternative 2 is **\$103,070,000**.

The estimated costs shown are (+/-30%) estimates in 2007 dollars and are based upon typical construction costs for previously performed similar construction. These estimated costs include all applicable labor and overheads associated with the engineering, design, and construction of these new PSCo facilities. This estimate did not include the cost for any other Customer owned equipment and associated design and engineering.

The following tables list the improvements required to accommodate the interconnection and the delivery of the Project. The cost responsibilities associated with these facilities shall be handled as per current FERC guidelines. System improvements are subject to change upon more detailed analysis.

Since this project intends to use the interconnection from the 600 MW Wind Facilities GI-2006-1(g) and GI-2006-2 at Pawnee Station, there will be only minimal

costs of \$38,400 associated with the interconnection required for this 200 MW expansion project GI-2006-4.

Table 3: Transmission Provider Interconnection Facilities (Customer Funded)

| Substation | Description | Cost |
|----------------------------------|--|-----------------|
| Pawnee 230kV Switchyard | Interconnect Customer's 230kV line to the existing Pawnee Switchyard. The major work required includes: <ul style="list-style-type: none"> • Engineering and design • Transmission line relaying and testing | \$23,000 |
| Lookout Operations Center | Add additional status/weather monitoring points for the Customer's generation at Lookout Operations Center. The major work required includes: <ul style="list-style-type: none"> • Programming and wiring changes | 15,400 |
| | Total Estimated Cost for PSCo Interconnection Facilities | \$38,400 |
| Time Frame | | 3 Months |

Table 4 – PSCo Network Upgrades for Delivery – Alternative 2

| Element | Description | Cost Est. Millions |
|-----------------------|---|--------------------|
| Pawnee Station | New 345 kV Line terminals to Daniels Park and Brick Center requiring the following equipment: <ul style="list-style-type: none"> • Six 345 kV, 2000 Amp, 40 kA circuit breakers • Two 345/230 kV 560 MVA autotransformers • Eight 345 kV 2000 Amp gang switches • required steel and foundations • Four 230 kV 40 kA, 3000 A, Circuit Breakers • Eight 230 kV Gang Switches • electrical bus work • metering, control, relaying and testing | \$13.47 |
| Daniels Park | New 345 kV Line Terminal to Pawnee. The following equipment will be required: <ul style="list-style-type: none"> • Three 345 kV 3000 Amp 50 kA circuit breakers • Six 345 kV 2000 Amp gang switches • misc. supporting steel and foundations • electrical bus work • associated metering control, relaying and testing | \$2.51 |

| Element | Description | Cost Est. Millions |
|--------------------------------|---|--------------------|
| Brick Center Substation | New 345 kV Yard with 230 kV yard expansion including two line terminals, one each to Daniels Park and Pawnee. This includes the following equipment: <ul style="list-style-type: none"> • Six 345 kV 3000 Amp 50 kA circuit breakers • Two 345/230 kV 560 MVA autotransformers • Fourteen 345 kV 2000 Amp, gang switches • Five 230 kV 3000 Amp, 50 kA circuit breakers • Eleven 230 kV gang switches • associated steel and foundations • associated metering, control, relaying and testing • electrical bus work | \$18.82 |
| 345 kV Transmission | Converting the existing 115-mile 230 kV line from Pawnee to Daniel Park Substation from 230 kV operation to 345 kV operation and converting the existing 80-mile 230 kV line from Pawnee to Brick Center Substation from 230 kV operation to 345 kV operation by reinsulating and reconductoring 80 miles of the existing Pawnee to Brick Center 230 kV line and the parallel Pawnee to Daniels Park 230 kV line for 345 kV operation. | \$21.68 |
| | Construct 35 miles of 345 kV double circuit transmission line which consists of rebuilding 15-miles of single circuit wood structures with double circuit 345 kV structures from Brick Center to just outside of Smoky Hill that currently make up the a portion of the Pawnee-Daniels Park 230 kV line and continue for 20 additional miles on existing corridor to Daniels Park. | \$27.33 |
| 230 kV Transmission | Operate one 345 kV double circuit from Brick Center to just outside of Smoky Hill at 230 kV. One circuit will continue on to Smoky Hill and the other to connect to the current double circuit structure that hold the existing Pawnee-Daniels Park 230 kV line making a Brick Center to Daniels Park 230 kV line. | \$14.88 |
| Siting and Permitting | Obtain necessary siting, permits, and ROW as required | \$4.34 |
| | Total Cost Estimate for PSCo Network Upgrades for Delivery | \$103.03 |
| | Total Cost of Project | \$103.07 |
| Time Frame | | 60 Months |

Assumptions for Alternatives

- The cost estimates provided are “scoping estimates” with an accuracy of +/- 30%.
- Estimates are based on **2007** dollars.
- There is no contingency added to the estimates.
- Labor is estimated for straight time only – no overtime included.
- Customer will be expanding their 3-breaker ring bus to a 4-breaker ring bus.
- No additional metering will be required.

- The Generator is not in PSCo's retail service territory. Therefore no costs for retail load metering are included in these estimates.
- This additional wind generation will utilize the existing/planned Peetz Logan Interconnect 230 kV transmission line.
- PSCo (or it's Contractor) crews will perform all construction and wiring associated with PSCo owned and maintained facilities.
- The estimated time for design and construction of PSCo network upgrades for interconnection at the Pawnee Station is at least 60 months, and is completely independent of other queued projects and their respective ISD's.
- It is anticipated that in order to construct the PSCo network upgrades for delivery, a Certificate of Public Convenience and Necessity (CPCN) will be required by the Colorado Public Utilities Commission (CPUC). The application for a CPCN will not be submitted until the Interconnection Agreement is fully executed. The estimated time frame for the CPCN process, siting, permitting, easement and right-of-way acquisition, design and construction for the PSCo network upgrades is at least 28 months from the time the Interconnection Agreement is fully executed. This time frame is also based on other identified assumptions for Siting and Land Rights, Substation Engineering and Transmission Engineering as listed below.
- Implementation of the recommended infrastructure for delivery will require that existing facilities be taken out of service for sustained periods. In most cases, these outages cannot be taken during peak load periods due to operational constraints. As a result, the estimated time frame for implementation could be increased by 3-6 months.
- A siting study will be required if network upgrades for delivery. Extensive public involvement is anticipated. Permit applications and possible minor right-of-way acquisition will be required. Land use permits will be required from multiple local jurisdictions.

Appendix A

Contingency Results

Table 5: Contingency Comparison Table of Most Significant Contingencies

| | Alternative # | | 1 | 2 | Contingency |
|--|---------------|--------------|-----------------------|---|--|
| | Rate | w/o Upgrades | Pawnee - Daniels Park | Pawnee - Daniels Park, Pawnee - Brick center - Daniels Park | |
| Overload Branches | Rate | w/o Upgrades | Pawnee - Daniels Park | Pawnee - Daniels Park, Pawnee - Brick center - Daniels Park | Contingency |
| Silver Saddle - Reunion 230 kV | 326 | 111 | 108 | 103 | Ft. Lupton - JL Green 230 kV |
| Beaver Creek TSGT - 230/115 kV auto | 224 | 131 | | | Beaver Creek TSGT - Beaver Creek WAPA 115 kV |
| Beaver Creek TSGT - Beaver Creek WAPA 115 kV | 200 | 145 | | | Beaver Creek TSGT - Beaver Creek WAPA 115 kV |
| Beaver Creek PSCo - 230/115 kV auto | 224 | 116 | | | Beaver Creek TSGT - 230/115 kV auto |
| Happy Canyon - Daniel Park 115 kV | 134.8 | 111 | | | Parker PSCo - Bayou 115 kV |
| Happy Canyon - Crowfoot 115 kV | 134.8 | 107 | | | Parker PSCo - Bayou 115 kV |
| Smoky Hill - Strassburg 115 kV | 144.6 | 105 | | | Quincy - Brick Center 230 kV |
| Castle Rock - Bayou 115 kV | 135 | | 108 | 101 | Daniels Park - 230/115 kV auto |
| Smoky Hill - Peakview 115 kV | 186.6 | 115 | 104 | | Smoky Hill - Murphy 230 kV |
| Pawnee - Brick Center 345 kV | 1200 | | | 106 | Pawnee - Daniels Park 345 kV |
| Pawnee - Daniels Park 345 kV | 1200 | | 100 | | Pawnee - Brick Center 345 kV |
| Washington - JL Green 230 kV | 495 | 108 | 100 | | Ft. Lupton - Henry Lake 230 kV |
| Ft. Lupton - 230/115 kV auto | 280 | | 105 | 102 | Valmont - Spindle #1 230 kV |
| Ft. Lupton - JL Green 230 kV | 495 | 111 | 104 | | Ft. Lupton - Henry Lake 230 kV |
| Ft. Lupton - St. Vrain #1 230 kV | 435 | 111 | 105 | | Ft. Lupton - St. Vrain #2 230 kV |
| Ft. Lupton - St. Vrain #2 230 kV | 435 | 111 | 105 | | Ft. Lupton - St. Vrain #1 230 kV |
| Homestead - Murphy 230 kV | 326 | 106 | | | Smoky - Peakview 115 kV |
| Daniels Park - 230/115 kV auto | 280 | | 118 | 115 | Castle Rock - Bayou 115 kV |
| Smoky Hill - Murphy 230 kV | 340 | 107 | | | Smoky - Peakview 115 kV |
| Brick Center 230/115 kV auto | 168 | 169 | 145 | | Quincy - Brick Center 230 kV |

Note: Peetz Logan total generation at 800 MW

Added Story - Beaver Creek 230 kV line mitigates contingency overloads around Beaver Creek

Added IREA projects improves 115 kV system around Smoky Hill

Peetz Logan - Pawnee impedance data revised